



# **Regulations and building codes for building integrated PV-systems in Europe**

## **IP PERFORMANCE Project**

*A science base on photovoltaics performance for increased  
market transparency and customer confidence*

**2008**

Composed by the Sub Project group "PV as a Building Product" of the IP Performance project, coordinated by ECN and supported and financed by the 6<sup>th</sup> Framework Programme for Research and Technological Development



## Contents

Contents .....	2
Summary .....	4
1 Introduction.....	5
1.1 Objective .....	5
1.2 State of the art .....	5
1.3 Description of work .....	5
1.4 Essential requirements .....	6
2 The Netherlands.....	7
2.1 Introduction.....	7
2.2 Mechanical resistance and stability .....	8
2.3 Safety in case of fire .....	11
2.4 Hygiene, health and the environment .....	12
2.5 Safety in use.....	14
2.6 Protection against noise .....	16
2.7 Energy, economy and heat retention.....	17
3 Germany .....	18
3.1 Introduction.....	18
3.2 Mechanical resistance and stability .....	19
3.3 Safety in case of fire .....	21
3.4 Hygiene, health and the environment .....	21
3.5 Safety in use.....	23
3.6 Protection against noise .....	24
3.7 Energy, economy and heat retention.....	25
4 Switzerland.....	26
4.1 Introduction.....	26
4.2 Mechanical resistance and stability .....	27
4.3 Safety in case of fire .....	30
4.4 Hygiene, health and the environment .....	32
4.5 Safety in use.....	32
4.6 Protection against noise .....	33
4.7 Energy, economy and heat retention.....	34
5 France .....	35
5.1 Introduction.....	35
5.2 Mechanical resistance and stability .....	36
5.3 Safety in case of fire .....	38
5.4 Hygiene, health and the environment .....	40

**D6.1.2 Building Codes BIPV in Europe**

5.5	Safety in use.....	42
5.6	Protection against noise .....	43
5.7	Energy, economy and heat retention.....	43
6	Austria .....	45
6.1	Introduction.....	45
6.2	Mechanical resistance and stability .....	46
6.3	Safety in case of fire .....	47
6.4	Hygiene, health and the environment .....	48
6.5	Safety in use.....	49
6.6	Protection against noise .....	50
6.7	Energy, economy and heat retention.....	52
7	Italy.....	53
7.1	Introduction.....	53
7.2	Mechanical resistance and stability .....	53
7.3	Safety in case of fire .....	56
7.4	Hygiene, health and the environment .....	56
7.5	Safety in use.....	57
7.6	Protection against noise .....	58
7.7	Energy, economy and heat retention.....	59
8	Spain .....	60
8.1	Introduction.....	60
8.2	Overview of standards and guidelines .....	60
9	European standards and IEC standards .....	67
9.1	Introduction.....	67
9.2	Mechanical resistance and stability .....	67
9.3	Safety in case of fire .....	70
9.4	Hygiene, health and the environment .....	72
9.5	Safety in use.....	73
9.6	Protection against noise .....	76
9.7	Energy, economy and heat retention.....	77
10	Results.....	78
11	Conclusions and recommendations.....	80
	Annex 1 Essential requirements as described in the CPD .....	81
	Annex 2 Summary Dutch Building Regulations .....	82

## Summary

To achieve a sustainable European market for building integrated photovoltaics (BIPV) it is crucial that building integrated PV (BIPV) products will meet the quality demands of the building sector in Europe. BIPV therefore should not only be compliant with electro technical standards but also be compatible with the existing building codes and practices. In this report an overview is given of the present standards and building codes of a number of European countries, which are leading or upcoming in BIPV.

For each country the standards and test procedures relevant for PV systems are categorized into the essential requirements according to the Construction Products Directive (CPD 89/106/EEC):

- 1 Mechanical resistance and stability
- 2 Safety in case of fire
- 3 Hygiene, health and the environment
- 4 Safety in use
- 5 Protection against noise
- 6 Energy, economy and heat retention

The categorization has been made for the different levels of PV systems: PV components (modules, inverters and support structures), installation and maintenance.

By making the inventory, it can be pointed out which categories are well standardized and which categories lack standardization. Also it can be seen at which level of the BIPV system the standards do apply.

The standardization and regulation on BIPV in Europe is a complex matter. In each country BIPV has to fulfill various regulations and (inter)national standards on electro technical as well as building technical level. Mainly, since BIPV has to deal with these two levels it is very difficult to give a complete and up-to-date overview of all BIPV related standards and guidelines in the selected European countries. However, the most relevant standards for BIPV are listed and, by giving an overview.

In a summarizing overview of involved European standards in the PV building area, it is pointed out where the hiatuses in BIPV standardization are given. On the subjects 'Mechanical resistance and stability', 'Safety in case of fire' and 'Safety in use' a larger number of standards available. It can be noticed that they are mainly focused on 'modules' and 'system', however. On the subjects 'Hygiene, health and the environment', 'Protection against noise' and 'Energy, economy and heat retention' only few standards are available.

This overview of building codes and regulations for BIPV products will form the basis for determining requirements for test procedures and PV codes to be set up in a following phase of this project.

# **1 Introduction**

## **1.1 Objective**

The main objective of deliverable 6.1.2 of the Performance Sub Project 6.1 is to draw up a report on the present regulations and building codes in the European Union.

## **1.2 State of the art**

To achieve a sustainable market for building integrated photovoltaics (BIPV) it is crucial that PV (building) products address the quality demands of the building sector. For this purpose they should not only be compliant with electro technical standards but also be compatible with the existing building codes and practices. The lack of standardization hinders the creation of a common European PV-building products market. In several previous projects like Prescript, Procede and Hip-Hip, building standards have been evaluated and best practices were disseminated.

In this sub-project an inventory of building codes, standards and regulations in PV Integrated building concepts is made. As already a lot of work has been done, the main activity in this report was to collect and update the available information and to range the standards and regulations into the essential requirements classification. Especially of use were the results of the project PRESCRIPT - Task 1 - Recommendations for testing PV roofs and facades. This overview of building codes and regulations for Building Integrated PV products will form the basis for determining requirements for test procedures and PV codes to be set up in deliverable 6.1.3.

## **1.3 Description of work**

In this report an overview of national regulations and building codes relevant for BIPV of a number of European countries is given. The countries that have been selected for the inventory are the countries that are leading in PV applications and have the most experience in embedding standards, regulations and test methods. The selected countries are The Netherlands, Germany, Switzerland and Austria. Although less experienced (but upcoming!) with BIPV also included are France, Italy and Spain.

For each country the standards and test procedures relevant for PV systems are classified into the essential requirements according to the Construction Products Directive (CPD 89/106/EEC). This has been done on the level of PV systems, PV components (modules, inverters and support structures), installation and maintenance. This gives a good insight in the availability and gaps in the standards and regulations on the essential requirements classes and product levels, and also in the overlap, gaps and contradiction between the involved countries. Based upon the available standard information per country a summarizing overview of European standards has been drawn up. The overview relates the essential requirements with the different elements of PV building applications. Furthermore conclusions are given concerning hiatuses of standards in the different PV building aspects related to the essential requirements.

## **D6.1.2 Building Codes BIPV in Europe**

---

During the inventory this approach proved to be not practical for Spain because of the complex structure of standards and the lack of sufficient PV building standard information. Therefore the available information is presented in a different lay-out.

In a next step of this sub-project a proposal will be made for modified or new standards and accompanying test procedures for PV systems for whole the European Union. As an example one can think of the Dutch NVN 7250 that focuses on building aspects of PV and solar thermal systems integrated in roofs and facades.

### **1.4 Essential requirements**

When PV is applied on buildings, the general standards that are applicable in the construction sector should be followed. The essential requirements for building products, as formulated in the Construction Products Directive (89/106/EEC, see for detailed information *Annex 1*) are classified in the following categories:

- 1 Mechanical resistance and stability
- 2 Safety in case of fire
- 3 Hygiene, health and the environment
- 4 Safety in use
- 5 Protection against noise
- 6 Energy, economy and heat retention

The extent to whether a requirement has an impact on the design of a PV building product depends largely on the interaction between building and PV system. This is often not realized leading to a too restricted set of requirements. It is important to stipulate that a whole range of the national building standards will in the near future (or already are) replaced by European building codes and that the national requirements will be expressed in relation to these European standards. Existing national deviations are obliged to be removed in the transition period (as far as possible) to prevent trades barriers within the European Union.

## 2 The Netherlands

### 2.1 Introduction

In The Netherlands all buildings have to fulfill the requirements laid down in the 'Bouwbesluit', Building Regulations, which form part of the 'Woningwet', the Dutch Housing Law. The Dutch building regulations describe all technical prescriptions for buildings under construction and for existing buildings. The regulations are divided into two groups: usage specific requirements and building specific requirements and are based on performance requirements. Building specific requirements comprise, among others, building physical and fire safety requirements and form the conditions for obtaining a building permit, which is supplied by the municipal authority.

Each part of the Building Regulations ends with a resolution of conformity that permits the building permit applicant to deviate from the specified functional requirements, for instance in the case of innovative elements like PV. For this purpose the applicant has to show a test report that proves that the functional requirements as required in the Building Regulations are met.

Dutch building regulations refer for the largest part to building standards and quality certificates. The buildings standards referred to may be standards from the NEN (Nederlands Normalisatie Instituut - Dutch Normalisation Institute) or European UEAtc standards. Quality certificates may be given by institutions that are recognized by the national Counsel of Accreditation. An example of a Dutch quality certificate is the KOMO mark. And additionally, in order to come to general adapted requirements for building connected (added or integrated).

For PV systems are developed some years ago a pre-standard for the building aspects of PV systems (NVN 7250 Solar Energy Systems – Integration in roofs and facades – Building Aspects, July 2007). Since a good installation of the system is also very important a Dutch installation guide is developed recently (ISSO 78 Handleiding Zonnestroom voor Ontwerper en Installateur, 2005). In this overview will be referred frequently to these documents. In case of European related Dutch standards the corresponding European standard is indicated (between brackets).

In *Annex 2* an overview is given of the applicable articles of the Dutch Building Regulations. These are summarized functional specific requirements. No attempt has been made to give a juridical correct translation. [Source PRESCRIPT - Task 1]

## 2.2 Mechanical resistance and stability

	Standards & guidelines	Title	Remarks
<b>Components</b>			
<i>Modules</i>	NEN-EN-IEC 61215:2005	Crystalline silicon terrestrial photovoltaic (PV) modules – Design qualification and type approval	Requirements for the design qualification and type approval of terrestrial photovoltaic modules suitable for long-term operation in general open air climates as defined in IEC 60721-2-1, applies to crystalline silicon.
	NEN 11646:1997 [IEC 61646]	Thin-film terrestrial photovoltaic (PV) modules – Design qualification and type approval	Lays down requirements for the type approval in moderate open-air climates. It is written with amorphous silicon technology in mind, but may also be applicable with other thin-film PV module types
	NEN-EN-IEC 61701:1999	Salt mist corrosion testing of photovoltaic (PV) modules	Determines the resistance of the module to corrosion from salt mist.
	NEN-EN 50380:2003	Datasheet and Nameplate Informations for Photovoltaic Modulus	Describes data sheet and nameplate information for non-concentrating photovoltaic modules.
	NEN 3569:2001	Safety glazing in buildings	Requirements for application of safety glazing in building
	NEN-EN-IEC 61730-1/2 (2007)	Photovoltaic (PV) module safety qualification Part 1: Requirements for construction Part 2: Requirements for testing	Part 1 describes the fundamental construction requirements for photovoltaic (PV) modules in order to provide safe electrical and mechanical operation during their expected lifetime. Part 2 describes the testing requirements for photovoltaic (PV) modules
	NEN 2608:1997 nl	Glass in building - Resistance against wind load - Requirements and determination method	Requirements and the determination methods for the bearing power for wind loading of vertically placed window panes in the facades of buildings, consisting of single panes or insulating double glazing
<i>Inverters</i>			
<i>Support structure</i>	NEN-EN-IEC 61215:2005	Crystalline silicon terrestrial photovoltaic (PV) modules – Design qualification and type approval	The constructive aspects of the support structure have to be tested on system level (in combination with the module, fixing parts etc.)
	NVN 7250, Clause 10.3	Requirements for applied materials – Sealing materials	(vulcanized) synthetic rubber profiles shall comply with the requirements in accordance with NEN 5656. When using foam band with NEN 3413, and glues, this shall comply with NVN 3412. Other sealing materials shall meet the requirements in accordance with ISO 11600.

## D6.1.2 Building Codes BIPV in Europe

	Standards & guidelines	Title	Remarks
	NVN 7250:2007 nl	Solar energy systems – Integration in roofs and facades – Constructional aspects	Chapter 5 Constructional requirements 5.1 Fundamental load combinations 5.2 Special load combinations 5.3 Interstitial condensation 5.4 Influence of temperature
<b>System</b>	NEN 6702: 2001	Technical principles for building structures; TGB 1990; loadings and deformations	loading/strength: no collapsing due to intermittent and special load Deformations/stiffness: $u \leq 0.004 \cdot l$
	NEN 6700 1991 incl. /A1:1997	Technical principles for building structures; TGB 1990	<i>Roof:</i> Test method (non-obligatory but recommended) ·Air-box method inducing air-lift (NEN 6707) ·Temperature differences (NEN 6702) ·Impulse load: sand-bag test (NEN 6702) <i>Facade:</i> Test method (obligatory) ·Structural wind resistance (positive & negative test (prEN12179-4, EN 77) · Impact resistance by Pendulum loading (pr EN 12600) ·Bending strength by pressurized gas (prEN 1288-2)
	NEN 6707: 2011/A1:2007	Fixing of roof coverings	Requirements and determination methods
	NEN 6710:1991 nl	TGB 1990 - Aluminium structures - Basic requirements and basic rules for calculation of predominantly statically loaded structures	Requirements made on the bearing power and the deformations of aluminium constructions, being part of building structures and parts thereof.
	NEN 6760:2001 incl. /C1:2002	TGB 1990 - Timber structures - Basic requirements and determination methods	Requirements for bearing constructions. This standard is applicable to static loaded wood constructions
	NEN 6770:1997 incl./A1:2001	TGB 1990 - Steel structures - Basic requirements and basic rules for calculation of predominantly statically loaded structures	Basic requirements and basic rules for calculation of predominantly statically loaded structures
	NEN-EN 12179:2000 en	Curtain walling - Structural wind resistance - Test Method	method for determining the resistance to wind load of curtain walling, both its fixed and openable parts, under positive and negative static air pressure
	NEN-EN 1991-1-4	Eurocode 1: Actions on structures – Wind	Part 1-4: General actions - Wind actions <i>Eurocode 1 will come in charge (including the National Annex) in 2010</i>
	NAD-NVN-ENV 1991-2-4: 1999	Eurocode 1: Basis of design and actions on structures - Part 2-4 - Actions on structures - Wind actions	Part 2-4 - Actions on structures - Wind actions <i>Eurocode 1 will come in charge (including the National Annex) in 2010</i>
ENV 1991-1-3: 2003	Eurocode 1: Actions on structures – Snow	Part 1-3: General actions - Snow loads <i>Eurocode 1 will come in charge (including the National Annex) in 2010</i>	

## D6.1.2 Building Codes BIPV in Europe

	Standards & guidelines	Title	Remarks
	ENV 1998 -1-1: 2005	Eurocode 8 - Design of structures for earthquake resistance	Part 1: General rules, seismic actions and rules for buildings <i>Eurocode 8 will come in charge (including the National Annex) in 2010 (check)</i>
	NPR 6708:1997 incl. /C1:1997	Fixing of roof coverings	Code of Practice
	NEN 2778: 1991nl	Moisture control in buildings	Determination methods
	NEN-EN 5601 Ontw. en	Hygrothermal performance of buildings	Resistance to wind-driven rain of roof coverings with discontinuously laid small elements - Test method
	NEN-EN 14437: 2004 en	Determination of the uplift resistance of installed clay or concrete tiles for roofing	Roof system test method
	NEN 3660:1998 nl	Window frames - Air permeability, rigidity and strength.	Methods of test.
	BRL 1511	National assessment guideline roof covering sheets and roof strips (under development)	Applicable for flexible roof covering materials (also in combination with flexible PV) Edit by INTRON Certification en KIWA
	NEN-EN-IEC 61701:1999	Salt mist corrosion testing of photovoltaic (PV) modules	Determines the resistance of the module to corrosion from salt mist.
	NVN 7250	Solar energy systems – Integration in roofs and facades – Constructional aspects	This pre-standard specifies the application of solar energy systems (or complete building elements with photovoltaic (PV) or thermal solar systems) as an integrated or stand-alone element of the external partition construction of buildings. It concerns roofs as well as facades of houses, residential buildings and commercial and industrial buildings.  11 Determination methods 11.1 Wind resistance 11.2 Interstitial condensation 11.3 Resistance to temperature changes 11.4 Frost resistance 11.5 Wind-spread fire test 11.6 Water tightness 11.7 Resistance to hail
	NEN-EN-ISO 6988:1994	Metallic and other non-organic coatings -	Sulfur dioxide test with general condensation of moisture
<b>Installation</b>	ISSO 78: Chapters 7, 8, 9 and 11	Guidance solar current for designer and installer	Chapter 5 Inverters for grid connection Chapter 7: Electrical device of grid connected PV system Chapter 8: Cabling Chapter 9: Installing and integration of PV systems Chapter 11: System control

**D6.1.2 Building Codes BIPV in Europe**

	<b>Standards &amp; guidelines</b>	<b>Title</b>	<b>Remarks</b>
<b>Maintenance</b>	ISSO 78: Chapters 11 and 12	Guidance solar current for designer and installer	Chapter 11: System control Chapter 12: Maintenance and failure detection

**2.3 Safety in case of fire**

	<b>Standards &amp; guidelines</b>	<b>Title</b>	<b>Remarks</b>
<b>Components</b>			
<i>Modules</i>			
<i>Inverters</i>			
<i>Support structure</i>			
<b>System</b>	NEN 6063:1991 incl. /A1:1997	Determination of the fire behavior of roofs on external exposure to flying brands	
	NEN 6065:1991 incl. /A1:1997	Determination of the contribution to fire propagation of building products	Fire classes: building material is tested for resistance to fire spread by a gas fired infra-red burner.
	NEN 6066: 1991/A1:1997	Determination of the smoke production during fire of building products	
	NEN 6068:2004/ A2: 2005	Determination of the resistance to fire movement between spaces	
	NEN 6069:2005 . /A1:2005	Determination of the fire resistance of elements of building constructions	
	NVN-ENV 1187:2003/A1:2005	Test methods for external fire exposure to roofs	Fire behavior of roofs on external exposure to flying brands. Basket filled with softwood fibers.
	NEN-EN 1991-1-2: 2002	Eurocode 1 - Actions on structures -	Part 1-2: General actions - Actions on structures exposed to fire <i>Eurocode 1 will come in charge (including the National Annex) in 2010</i>

**D6.1.2 Building Codes BIPV in Europe**

	<b>Standards &amp; guidelines</b>	<b>Title</b>	<b>Remarks</b>
	NVN 7250,	Solar energy systems – Integration in roofs and facades – Constructional aspects	This pre-standard specifies the application of solar energy systems (or complete building elements with photovoltaic (PV) or thermal solar systems) as an integrated or stand-alone element of the external partition construction of buildings. It concerns roofs as well as facades of houses, residential buildings and commercial and industrial buildings.  Chapter 6 Requirements regarding fire safety 6.1 Restricting the occurrence of a flammable situation 6.2 Restricting the development of fire 6.3 Restricting the spread of fire 6.4 Protection against lightning
			Chapter 10 Requirements on the materials used 10.2 Anti-corrosion 10.3 Sealing materials
			11 Determination methods 11.5 Wind-spread fire test
<b>Installation</b>	NEN 1014:1992 incl. /C2:2000	Protection against lightning	In combination with NTA 8011 (Maxwell principle is applicable)
	ISSO 78: Clauses 7.8 and 7.9	Solar current for designer and installer	Clause 7.8: Earthing Clause 7.9: Lightning
<b>Maintenance</b>			

**2.4 Hygiene, health and the environment**

	<b>Standards &amp; guidelines</b>	<b>Title</b>	<b>Remarks</b>
<b>Components</b>			
<i>Modules</i>			
<i>Inverters</i>			

## D6.1.2 Building Codes BIPV in Europe

	Standards & guidelines	Title	Remarks
<i>Support structure</i>	NVN 7250,	Solar energy systems – Integration in roofs and facades – Constructional aspects	This pre-standard specifies the application of solar energy systems (or complete building elements with photovoltaic (PV) or thermal solar systems) as an intergrated or stand-alone element of the external partition construction of buildings. It concerns roofs as well as facades of houses, residential buildings ans commercial and industrial buildings. 7 Requirements regarding noise 7.1 Protection against outdoor noise 7.2 Sound-proofing between rooms
			10 Requirements on the materials used 10.1 Dangerous substances 10.2 Anti-corrosion 10.3 Sealing materials 10.4 Resistance to hail
<b>System</b>	NEN 2686:1988 nl	Air leakage of buildings	Method of measurement
	NEN 2778:1991 incl. /A3:2004	Moisture control in buildings	Determination methods
	NEN 5656:1993 nl	Rubber building gaskets; solid, load bearing and non-load bearing gaskets	Specification and methods of test
	EN 12154: 1999 and EN 12155: 2000	Curtain walling	EN 12154: Water tightness- Performance requirements and classification EN 12155: Water tightness – laboratory test under static pressure
	Ontw. NEN 3661:1995	Window frames - Air permeability, Water tightness, rigidity and strength, specifications	
	EN 86	Testing of windows. Water tightness under static pressure	
	prEN 12154	Curtain walling. Water tightness. Performance requirements and classification	Classes: water spray with zero pressure and water spray with pressure difference
	prEN 12155	Curtain walling. Water tightness. Laboratory test under static pressure	
	NPR 2877:1991 nl	Test methods of the water tightness of partition constructions	
	Dutch Building Regulations	Health Protection against vermin	Design rule: unsealed openings < 0.01 diameter
	Dutch Building Regulations	Health Protection against harmful materials	Design rule: Avoid use of unacceptable, poisonous, irritating or ionising materials
<b>Installation</b>			

**D6.1.2 Building Codes BIPV in Europe**

	Standards & guidelines	Title	Remarks
<b>Maintenance</b>			

**2.5 Safety in use**

	Standards & guidelines	Title	Remarks
<b>Components</b>			
<i>Modules</i>	NTA 8494:2004	Qualification measurements for grid-connected (PV) inverters	
	EN 50380	Datasheet and Nameplate Information for Photovoltaic Modules	
	NEN-EN-IEC 61730-1:2007 en; fr	Photovoltaic (PV) module safety qualification	Part 1: Requirements for construction
	NEN-EN-IEC 61730-2:2007 en; fr	Photovoltaic (PV) module safety qualification	Part 2: Requirements for testing
	NEN 10891:1994 en;fr [IEC 60891:1987-04]	Procedures for temperature and irradiance corrections to measured I-V characteristics of crystalline silicon photovoltaic devices	<i>Related to IEC 60891:1987 IDT, IEC 60891:1987/A1:1992 IDT, EN 60891:1994 IDT</i>
	TEC 60904 series	Photovoltaic devices.	The IEC 60904 series is a coherent system of standards for defining the electrical features of PV devices. These standards are mainly for interest of manufacturers, test labors and research institute and of minor interest of end-users
	IEC 60904-1	Photovoltaic devices.	Part 1: Measurement of photovoltaic current-voltage characteristics
	IEC 60904-2.	Photovoltaic devices.	Part 2: Requirements for reference solar cells
	IEC 60904-3	Photovoltaic devices. with spectral irradiance data	Part 3: Measurement principles for terrestrial photovoltaic (PV) solar devices with spectral irradiance data
	IEC 60904-5	Photovoltaic devices.	Part 5: Determination of the equivalent cell temperature (ECT) of photovoltaic (PV) devices by the open circuit method
	IEC 60904-6	Photovoltaic devices.	Part 6: Requirements for reference solar modules
	IEC 60904-7	Photovoltaic devices.	Part 7: Computation of spectral mismatch error introduced in the testing of a photovoltaic device
	IEC 60904-8 : 1998 en; fr	Photovoltaic devices.	Part 8: Measurement of spectral response of a photovoltaic (PV) device

## D6.1.2 Building Codes BIPV in Europe

	<b>Standards &amp; guidelines</b>	<b>Title</b>	<b>Remarks</b>
	IEC 60904-9 : 1995 en ; fr	Photovoltaic devices.	Part 9: Solar simulator performance requirements
	IEC 60904-10 : 1998 en ; fr	Photovoltaic devices.	Part 10: Methods of linearity measurement
<i>Inverters</i>	NTA 8494 (EN)	Qualification measurements for grid connected PV systems	NTA 8494 gives requirements for the design qualification of inverters for grid connected photovoltaic (PV) systems.
	IEC 60755:1983 + A1: 1983 + A2: 1983	General requirements for residual current operating protective devices	The primary function of residual current devices is to give protection against "indirect contact", but with devices of adequate sensitivity (that is units having operating residual currents not exceeding 30 mA) there is the additional benefit that, should other methods of protection fail, the device will give a high degree of protection to a user making direct contact with a live conductive part
	IEC 60950:1999-04 en;fr	Safety of information technology equipment	
	NEN-EN-IEC 61000-6-3:2001 en;fr	Electromagnetic compatibility (EMC) - Part 6-3: Generic standards - Emission standard for residential, commercial and light-industrial environments	Outlines the emission requirements which applies to electrical and electronic apparatus intended for use in the residential, commercial and light-industrial environment for which no dedicated product or product-family emission standard exists. Disturbances in the frequency range 0 Hz to 400 GHz are covered. Apparatus designed to radiate electromagnetic energy for communication purposes are excluded from this standard.
	IEC 62109	IEC 62109-2 ED.1. Safety of Power Converters for use in Photovoltaic Power Systems. Part 2. Particular requirements for inverters	
	NTA 8030	Guidelines for product specification of grid connected inverters for Distributed Energy Resources (DER)	This document gives requirements for the product specifications of inverters for grid connected Distributed Energy Resources (DER) for single phase or multi phase connections feeding up to 25 A per phase into the utility low voltage grid.
<i>Support structure</i>			
<b>System</b>	NEN 1010.	Safety requirements for low-voltage installations Chapter 7.712	
	EN 50160.	Voltage characteristics of electricity supplied by public distribution systems	

**D6.1.2 Building Codes BIPV in Europe**

	<b>Standards &amp; guidelines</b>	<b>Title</b>	<b>Remarks</b>
	NTA 8013: 2003	Procedure for inspection of PV-systems.	
	NTA 8011 (NL)	Security definition for low voltage installations	Additional to the NEN 1010
	NTA 8493 (EN)	Small grid connected PV systems	For small PV-systems.
<b>Installation</b>	ISSO-78 Chapter 7	Guidance solar current for designer and installer	Electrical device
	NEN 1014:1992 incl. /C2:2000	Protection against lightning	In combination with NTA 8011 (Maxwell principle is applicable)
	NEN-EN 50110: 1998/C1:2001 en	Operation of electrical installations (National Annexes)	
	NEN 3140: 1998 nl	Operation of electrical installations - Additional Netherlands requirements for low-voltage installations	Also a practical guidance available to NEN 3140
<b>Maintenance</b>			

**2.6 Protection against noise**

	<b>Standards &amp; guidelines</b>	<b>Title</b>	<b>Remarks</b>
<b>Components</b>			
<i>Modules</i>			
<i>Inverters</i>			
<i>Support structure</i>			
<b>System</b>	NEN 5077:2001	Noise control in buildings	Determination methods for performances concerning airborne sound insulation, impact sound insulation, sound-proofing of partitions and sound levels caused by technical services
	NPR 5272:2003	Noise control in buildings	Directions for the application of the calculation method for noise control of façades based on NEN-EN 12354-3
	NEN-EN 12354-3: 2000	Building acoustics	Estimation of acoustic performance of buildings from the performance of elements; Part 3: Airborne sound insulation against outdoor sound

**D6.1.2 Building Codes BIPV in Europe**

	<b>Standards &amp; guidelines</b>	<b>Title</b>	<b>Remarks</b>
<b>Installation</b>	IEC 60364-7-714:1996 en;fr	Electrical installations of buildings - Part 7: Requirements for special installations or locations - Section 714: External lighting installations	The requirements of part 7 supplement, modify or replace certain of the general requirements of the IEC 364. The numbers following the particular number of section 714 are those of the corresponding parts, chapters, sections or clauses of IEC Publication 364. The absence of reference to a chapter, a section or a clause means that the general requirements of IEC 364 are applicable.
<b>Maintenance</b>			

**2.7 Energy, economy and heat retention**

	<b>Standards &amp; guidelines</b>	<b>Title</b>	<b>Remarks</b>
<b>Components</b>			
<i>Modules</i>			
<i>Inverters</i>			
<i>Support structure</i>			
<b>System</b>	NEN 5128	Energy performance of dwellings and residential buildings - determination method	This standard gives the terminology and determination methods of the energy performance of dwellings and residential buildings. Chapter 14: Calculation of the energy contribution of photovoltaic solar systems
	NEN 1068:2001 incl. /A1:2001	Thermal insulation of building -	Calculation methods
	NEN 2916	Energy performance of utility buildings - determination method	This standard gives terminology, definitions and methods for the energy performance of a building or a part of a building.
	(prEN 12152)	Limitation of air permeability	Classes: different pressure levels are applied by which the air permeability $m^3/m^2/h$ is measured.
	(ISO 8990:1994)	Steady-state thermal transmission properties	calibrated guarded hot box: U-value
<b>Installation</b>			
<b>Maintenance</b>			

## 3 Germany

### 3.1 Introduction

In Germany all components which are used for the construction of a building are treated as construction products with different levels of demands according to their application.

The Council of the European Communities (CPD, 89/106/EEC) defines construction products as following: "..., 'construction product' means any product which is produced for incorporation in a permanent manner in construction works, including both buildings and civil engineering works."

Requirements for construction products are regulated in the building regulations of the 'Bundeslaender' (federal states). The applicability has to be proved for all construction products. The proof of applicability depends on the kind of construction products. Construction products can be either regulated or non-regulated.

For regulated construction products technical standards have to exist. A standard is initially a voluntary agreement of the persons who formulated it. Standards are non-binding. For instance, a manufacturer needs not to follow standards. However, standards gain indirect importance by mentioning in laws. Standards are important for construction products because they are necessary to prove the applicability. The proof is verified if the product corresponds with the technical rules of standard.

Construction products are non-regulated if either no standard exists or the product clearly deviates from an existing standard. The applicability has to be proved separately for a general non-regulated construction product. There are two possibilities to prove this applicability. Every manufacturer can get the 'Allgemeine bauaufsichtliche Zulassung' (general certificate of approval) for his own construction product. Alternatively, the building owner needs the 'Zustimmung im Einzelfall' (approval to special case), if no standard and no 'Allgemeine bauaufsichtliche Zulassung' exist. Both possibilities cause higher costs and sometimes much more time.

The conformity of the construction product has to be proved by several kinds of marking. The kind of marking depends on the kind of construction products and on the kind of standards. Generally, the kind of marking depends on the level of risk of the respective construction product as well.

In Germany on-top roof-mounted PV modules are regarded as "other construction products" (übrige Bauprodukte). In that case additional tests or the fulfillment of further building specific standards are not necessary.

Like in the Netherlands in Germany several guides for installing PV systems exists. An extensive guide is 'Planning and installing Photovoltaic systems', from the German Society for solar energy (DGS, 2002).

### 3.2 Mechanical resistance and stability

	Standards & guidelines	Title	Remarks
<b>Components</b>			
<i>Modules</i>	DIN EN 611215 Ed. 2:2005	Crystalline silicon terrestrial photovoltaic (PV) modules - Design qualification and type approval	
	DIN EN 61646:2006[]	Thin-film terrestrial photovoltaic (PV) modules - Design qualification and type approval	
	DIN-EN-IEC 61701:2000	Salt mist corrosion testing of photovoltaic (PV) modules	
	DIN EN 50380:2003	Data sheet and name plate information for photovoltaic modules	
	E DIN VDE 0126-21:2007	Photovoltaik im Bauwesen (Photovoltaics in the building sector)	Draft from 19.7.2007, own translation
	DIN EN 61730-1 Ed.2:2006	Photovoltaic (PV) module safety qualification	Part1: Requirements for construction
	DIN EN 61730-2 Ed.2:2006	Photovoltaic (PV) module safety qualification –	Part1: Requirements for testing
	DIN EN 410:1998	Glass in building	Determination of luminous and solar characteristics of glazing
	DIN EN 572-1:2004	Glass in building - Basic soda lime silicate glass products -	Part 1: Definitions and general physical and mechanical properties
	DIN EN 572-2	Glass in building - Basic soda lime silicate glass products	Part 2: Float glass
	EN 12150-1:2000	Glass in building - Thermally toughened soda lime silicate safety glass	Part 1: Definition and description
	DIN EN 572-1:2004	Glass in building - Basic soda lime silicate glass products -	Part 1: Definitions and general physical and mechanical properties
	E DIN 18008-1:2006	Glass in Building - Design and construction rules -	Part 1: Terms and general bases (draft)
	E DIN 18008-2:2006	Glass in building - Design and construction rules -	Part 2: Linearly supported glazings (draft)

**D6.1.2 Building Codes BIPV in Europe**

	<b>Standards &amp; guidelines</b>	<b>Title</b>	<b>Remarks</b>
	DIN EN ISO 12543-1:1998	Glass in building - Laminated glass and laminated safety glass -	Part 1: Definitions and description of component parts
	DIN EN ISO 12543-2:1998 + A1:2004	Glass in building - Laminated glass and laminated safety glass -	Part 2: Laminated safety glass
<i>Inverters</i>			
<i>Support structure</i>			
<b>System</b>	DIN 1055-4	Action on structures-	Part 4: Wind loads
	DIN 1055-5	Action on structures-	Part 5: Snow loads and ice loads
	DIN 1055-100:2001	Actions on structures -	Part 100: Basis of design, safety concept and design rules
	EN 1991-1-1:2002	Eurocode 1: Actions on structures -	Part 1-1: General actions; Densities, self-weight, imposed loads for buildings
	DIN 18516-4:1990	Back-ventilated, non-load bearing, external enclosures of buildings, made from tempered safety glass panels;	requirements and testing
	E DIN EN 12488	Glass in building - Glazing requirements	Assembly rules (draft soon)
	EN 13830:2003	Curtain walling - Product standard	
	DIN EN 61721:1999	Susceptibility of a photovoltaic (PV) module to accidental impact damage	Resistance to impact test
	Deutsche Gesellschaft für Sonnenenergie (DGS)	Photovoltaische Anlagen, Leitfaden für Elektriker, Dachdecker, Fachplaner. Architekten und Bauherren	General guide for planning and installation for grid-connected and stand-alone systems, chapter 5: Planning and Design of grid-coupled systems and Chapter 8: Mounting Systems and Building Integration
<b>Installation</b>	Deutsche Gesellschaft für Sonnenenergie (DGS)	Photovoltaische Anlagen, Leitfaden für Elektriker, Dachdecker, Fachplaner. Architekten und Bauherren	General guide for planning and installation for grid-connected and stand-alone systems, Chapter 9: Installation
<b>Maintenance</b>			

### 3.3 Safety in case of fire

	Standards & guidelines	Title	Remarks
<b>Components</b>			
<i>Modules</i>	DIN 4102-2	Fire behaviour of Building Materials and Building Components; Building Components; Definitions, Requirements and Tests	
	DIN 4102-7	Fire behaviour of building materials and building components - Part 7: Roofing; definitions, requirements and testing	For roof integrated solutions
<i>Inverters</i>			
<i>Support structure</i>			
<b>System</b>	DIN 4102-2	Fire Behaviour of Building Materials and Building Components;	Definitions, Requirements and Tests
	DIN 4102-7	Fire behaviour of building materials and building components -	Part 7: Roofing; definitions, requirements and testing
<b>Installation</b>			
<b>Maintenance</b>			

### 3.4 Hygiene, health and the environment

	Standards & guidelines	Title	Remarks
<b>Components</b>			
<i>Modules</i>			
<i>Inverters</i>	DIN VDE 0126-1-1:2006	Automatic disconnection device between a generator and the public low-voltage grid	
<i>Support structure</i>			

**D6.1.2 Building Codes BIPV in Europe**

	<b>Standards &amp; guidelines</b>	<b>Title</b>	<b>Remarks</b>
<b>System</b>	DIN EN 61173:1994	Over voltage protection for photovoltaic (PV) power generating systems - (IEC 61173:1992)	Guide (IEC 61173:1992)
	DIN EN 62305-1:2006	Protection against lightning -	Part 1: General principles (IEC 62305-1:2006)
	DIN EN 62305-2:2006	Protection against lightning -	Part 2: Risk management (IEC 62305-2:2006)
	DIN EN 62305-3:2006	Protection against lightning -	Part 3: Physical damage to structures and life hazard (IEC 62305-3:2006, modified)
	DIN EN 62305-4:2006	Protection against lightning -	Part 4: Electrical and electronic systems within structures (IEC 62305-4:2006)
	89/336/EWG Mitt 2006-12; 06/C314/05:2006	Commission communication in the framework of the implementation of the Council directive 89/336/EEC of 3 May 1989	On the approximation of the laws of the Member States relating to electromagnetic compatibility
	73/23/EWG Mitt 2000; 00/C104/07:2000	Commission opinion of 30 March 2000 within the framework of Council Directive 73/23/EEC	Relating to electrical equipment designed for use within certain voltage limits
DIN 18055:1981	Windows; air permeability of joints, water tightness and mechanical strain; requirements and testing		
	Deutsche Gesellschaft für Sonnenenergie (DGS)	Photovoltaische Anlagen, Leitfaden für Elektriker, Dachdecker, Fachplaner, Architekten und Bauherren	General guide for planning and installation for grid-connected and stand-alone systems
<b>Installation</b>	BGV C22	Bauarbeiten (building works)	national regulation, no standard: Berufsgenossenschaftliches Vorschriften und Regelwerk zum Arbeitsschutz und Unfallverhütung, Described is the erection and use of scaffolds or other means for work on the roof, use of personal protection equipment,
<b>Maintenance</b>			

### 3.5 Safety in use

	<b>Standards &amp; guidelines</b>	<b>Title</b>	<b>Remarks</b>
<b>Components</b>			
<i>Modules</i>			
<i>Inverters</i>	EN 60529:1991 + A1:2000	Degrees of protection provided by enclosures (IP code)	(IEC 60529:1989 + A1:1999)
	IEC 62109-1	Safety of power converters for use in photovoltaic systems	Part 1: General requirements
	DIN VDE 0126-1-1	Automatic disconnection device between generator and the public low-voltage-grid	
	DIN EN 60146-1-1:1993	Semiconductor convertors; general requirements and line-commutated convertors;	part 1-1: specifications of basic requirements (IEC 60146-1-1:1991); draft 2007 available
	DIN EN 60146-1-3:1993	Semiconductor convertors; general requirements and line-commutated convertors;	part 1-3: transformers and reactors (IEC 60146-1-3:1991)
<i>Support structure</i>			
<b>System</b>	DIN VDE 0100-712	Low-voltage installations - Part 7-712: Requirements for special installations or locations -	Solar photovoltaic (PV) power supply systems (IEC 60364-7-712:2002, modified); German implementation HD 60364-7-712:2005 + Corrigendum:2006
	DIN VDE 0298-3:2006	Application of cables and cords in power installations -	Part 3: Guide to use of non-harmonized cables
	DIN VDE 0298-4:2003	Application of cables and cords in power installations -	Part 4: Recommended current-carrying capacity for sheathed and no sheathed cables for fixed wirings in and around buildings and for flexible cables and cords
	DIN EN 60947-1:2004	Low-voltage switchgear and control gear -	Part 1: General rules (IEC 60947-1:2004)
	DIN 18200:2000	Assessment of conformity for construction products -	Certification of construction products by certification body
<b>Installation</b>	DIN EN 50178:1997	Electronic equipment for use in power installations	
	DIN VDE 0603-1:1996	Consumer units and meter panels AC 400 V;	consumer units and meter panels

**D6.1.2 Building Codes BIPV in Europe**

	<b>Standards &amp; guidelines</b>	<b>Title</b>	<b>Remarks</b>
	DIN VDE 0603-2:1998	Customer distribution boards and meter panels AC 400 V -	Part 2: Main line branch terminals
	DIN VDE 0603-3:2004	Consumer distribution boards and meter panels AC 400 V -	Part 3: Terminal connectors for meters
	DIN VDE V 0603-5:2006	Consumer distribution boards and meter panels AC 400 V -	Part 5: Device for mounting and connection (BKE) of electronic meters (eHZ) for household use on meter panels (draft)
<b>Maintenance</b>	DIN IEC 62446; VDE 0126-23:2007	Grid connected photovoltaic systems -	Minimum system documentation, commissioning tests and inspection requirements (IEC 82/460/CD:2006); draft

**3.6 Protection against noise**

	<b>Standards &amp; guidelines</b>	<b>Title</b>	<b>Remarks</b>
<b>Components</b>			
<i>Modules</i>			
<i>Inverters</i>			
<i>Support structure</i>			
<b>System</b>	DIN EN ISO 717-1:1996 + A1:2006	Acoustics - Rating of sound insulation in buildings and of building elements -	Part 1: Airborne sound insulation (ISO 717-1:1996 + AM1:2006)
	DIN 4109 :1989-11	Sound insulation in buildings; requirements and testing	Schallschutz im Hochbau; Anforderungen und Nachweise
<b>Installation</b>			
<b>Maintenance</b>			

### 3.7 Energy, economy and heat retention

	<b>Standards &amp; guidelines</b>	<b>Title</b>	<b>Remarks</b>
<b>Components</b>			
<i>Modules</i>	DIN EN 674:1997	Glass in building - Determination of the thermal transmittance (U value) -	Guarded hot plate method
	EN 675:1997	Glass in building - Determination of the thermal transmittance (U value) -	Heat flow meter method
<i>Inverters</i>			
<i>Support structure</i>			
<b>System</b>	ISO 12543-1	Glass in building - Laminated glass and laminated safety glass -	Part 1: Definitions and description of component parts
<b>Installation</b>			
<b>Maintenance</b>			

## 4 Switzerland

### 4.1 Introduction

In Switzerland all buildings have to fulfil the requirements laid down in a company of private law named SIA (Swiss society of engineers and architects). It has a federalist structure and is composed of active sections on a regional level, four occupational classes and specialized companies which encourage the exchange at the occupational level. Moreover, more than one hundred commissions and working groups take care of the development and the update of the collection of standards SIA in different languages and the representation of the Swiss interests within the framework of European standardization.

The standards collection of the SIA is subdivided into contractual standards, technical standards and standards aimed at the understanding. The technical standards are positioned at product level, building elements (systems), build works and society.

In Switzerland, the coordinator of the fire protection is AEAI "Association des établissements cantonaux d'assurance incendie", is also the organization of certification accredited by the Swiss confederation for products and persons in the field of fire protection and the head of the cantonal authorities organization and of 19 cantonal institutions of insurance.

The building permits for PV systems are required only by some cantons (region).

According to information provided by the Swiss Government for Swiss Exporters the CE Mark is not compulsory in Switzerland except for products for export to the European Union.

No BIPV standard exist in Switzerland.

#### *Additional remarks:*

- The main standards are in French and German languages. The translation in English has been made but to maintain the right title, you find in the remarks the French title.
- The SIA is a company of private law. It has a federalist structure and is composed of active sections on a regional level, four occupational classes and specialized companies which encourage the exchange at the occupational level. Moreover, more than one hundred commissions and working groups take care of the development and the update of the collection of standards SIA and the representation of the Swiss interests within the framework of European standardization

#### *References:*

[www.sia.ch](http://www.sia.ch)

[www.kgvonline.ch](http://www.kgvonline.ch)

[http://www.electrosuisse.ch/cms.cfm/s\\_page/70510](http://www.electrosuisse.ch/cms.cfm/s_page/70510)

## 4.2 Mechanical resistance and stability

	Standards & guidelines	Title	Remarks
<b>Components</b>			
<i>Modules</i>	SN EN 61215:1995 [IEC 61215]	Crystalline silicon terrestrial photovoltaic (PV) modules – Design qualification and type approval	
	SN EN 61646:1997 [IEC 61646]	Thin-film terrestrial photovoltaic (PV) modules – Design qualification and type approval	
	SN EN 61701:1999	Salt mist corrosion testing of photovoltaic (PV) modules	
	SN EN 50380:2003	Datasheet and nameplate information for photovoltaic modules	Remarks: Can be add mechanical / optical / thermal data, not only electrical data
	SN EN 61721:1999	Susceptibility of a photovoltaic (PV) module to accidental impact damage (resistance to impact test)	Remarks: Can be cancelled and replace by SN EN 61730-2  -Is no more valid in Switzerland (21.09.07)
	SN EN 61730-1:2007	Photovoltaic (PV) module safety qualification. Part 1: Requirements for construction	
	SN EN 61730-2:2007	Photovoltaic (PV) module safety qualification - Part 2: Requirements for testing	
	SN EN 61345:1998	UV test for photovoltaic (PV) modules	

## D6.1.2 Building Codes BIPV in Europe

	Standards & guidelines	Title	Remarks
<i>Inverters</i>	SN EN 62093:2005	Balance-of-system components for photovoltaic systems - Design qualification natural environments	This International Standard establishes requirements for the design qualification of balance-of system (BOS) components used in terrestrial photovoltaic (PV) systems. This standard is suitable for operation in indoor, conditioned or unconditioned; or outdoor in general open-air climates as defined in IEC 60721-2-1, protected or unprotected.
	SN EN 61000-6-1 SN EN 61000-6-2 SN EN 61000-6-3 SN EN 61000-6-4 SN EN 61000-3-2 SN EN 61000-3-3	Electromagnetic compatibility (EMC).	
<i>Support structure</i>			
<b>System</b>	SIA 261 (Eurocodes) SN 505160	Actions on Structures	English translation of : Action sur les structures porteuses ***** Description words: Construction, Effects, Loading, Structures, Stress
	SIA 232.701 SN EN 14437	Determination of the uplift resistance of installed clay or concrete tiles for roofing - Roof system test method	Description words: Bricks, Construction, Construction materials, Definition, Definitions, Physical properties, Resistance, Resistors, Roof covering, Roof coverings, Roof systems, Roofing, Roofing tiles, Sampling methods, Surface soundness, Take-off, Testing, Uplift resistance, Weathering, Wind loading, Wind resistance
	SIA 263 SN 505263	Steel structures	

## D6.1.2 Building Codes BIPV in Europe

	Standards & guidelines	Title	Remarks
	SIA 164.065 SN EN 380	Timber structures - Test methods - General principles for static load testing	English translation of : Structures en bois - Méthodes d'essais - Principes généraux d'essais par chargement statique  Description: The document specifies the general principles to be adopted for static load testing of timber structures. Where necessary, it should be verified by test that a structure complies with stated criteria. Relevant parts may be used for proof loading or for the testing of structures in service. It is not intended to be used for testing of individual pieces of timber, individual joints or structural scaled models
	SIA V161.021 SN ENV 1999-1-1	Eurocode 9: Design of aluminium structures - Part 1-1: General structural rules	
	SIA 331 SN 563331	Windows	Description words: Acceptance specification, Components, Construction, Construction of windows, Design, Glazing, Performance, Windows
	SIA V280 SN 564280	Waterproofing membrane in synthetic material	English translation of : Lés d'étanchéité en matière synthétique (Les polymères) - Performances exigées et essais des matériaux *****  Remarks: Recommandation not standard! contains a lot of test. Can be used to test i.e Uni- Solar modules on flat roof  Description words: Construction, Planning, Plastics, Properties, Roof decking, Sealing,

## D6.1.2 Building Codes BIPV in Europe

	Standards & guidelines	Title	Remarks
			Testing, Vapour barriers, Water proof sheetings
<b>Installation</b>			
<b>Maintenance</b>			

### 4.3 Safety in case of fire

	Standards & guidelines	Title	Remarks
<b>Components</b>			
<i>Modules</i>	SN EN 61730-2:2007	Photovoltaic (PV) module safety qualification - Part 2: Requirements for testing (IEC 61730-2:2004, modified)	Description words: Applicability classes, Earthing, Insulation test, Leakage currents, Mechanical testing, Photovoltaics, Qualification approval, Qualifications, Safety measures, Safety requirements, Solar cells, Solar energy, Solar power, Solar technics, Temperature test, Testing, Visual inspection (testing)
<i>Inverters</i>			
<i>Support structure</i>			
<b>System</b>	SIA 261 SN 505261	Actions on Structures	Actions sur les structures porteuses  Description words : Construction, Effects, Loading, Structures, Stress
	SIA 183.052/183.055 SN EN 13501-2/5	Fire classification of construction products and building elements - Part 2: Classification using data from fire resistance tests, excluding ventilation services / - Part 5: Classification using data from external fire exposure to roofs tests	Classement au feu des produits et éléments de construction – Partie-2 : Classement à partir des données d'essais de résistance au feu Partie-5 : Classement utilisant des données d'essais au feu des toitures exposées à un feu extérieur

## D6.1.2 Building Codes BIPV in Europe

	<b>Standards guidelines</b>	<b>&amp; Title</b>	<b>Remarks</b>
	SIA 183.101/183.102/ SN EN 1363-1/-2	Fire resistance tests - Part 1: General requirements	Essais de résistance au feu Partie 1: Exigences générales Partie 2: Modes opératoires de substitution ou additionnels
	SIA 183.301/183.302 SN EN ISO 1182 SN EN ISO 1716	Reaction to fire tests for building products - Non-combustibility test (ISO 1182:2002) / Determination of the heat of combustion (ISO 1716:2002)	Essais de réaction au feu des produits de construction - Essai d'incombustibilité (ISO 1182:2002) / Détermination de la chaleur de combustion (ISO 1716:2002)
	SIA 183.305/183.306 SN EN ISO 11925-2 / SN EN 13823	Reaction to fire tests - Ignitability of building products subjected to direct impingement of flame - Part 2: Single-flame source test (ISO 11925- 2:2002) / Reaction to fire tests for building products - Building products excluding floorings exposed to the thermal attack by a single burning item	Essais de réaction au feu - Allumabilité des produits de bâtiment soumis à l'incendie directe de la flamme - Partie 2: Essai à l'aide d'une source à flamme unique (ISO 11925- 2:2002) /Essais de réaction au feu des produits de construction - Produits de construction à l'exclusion des revêtements de sol exposés à une solicitation thermique provoquée par un objet isolé en feu
	SIA 183.501 SN ENV 1187	Testing methods for the exposure of the roofs to an external fire	Méthodes d'essai pour l'exposition des toitures à un feu extérieur
	SIA 232.201 SN EN 501	Roofing products from metal sheet - Specification for fully supported roofing products of zinc sheet	Produits de couverture en tôle métallique - Spécification pour les produits de couverture en feuille de zinc totalement supportés
<b>Installation</b>			
<b>Maintenance</b>			

#### 4.4 Hygiene, health and the environment

	Standards guidelines	&	Title	Remarks
<b>Components</b>				
<i>Modules</i>				
<i>Inverters</i>				
<i>Support structure</i>				
<b>System</b>	SIA 112.1		Sustainability to the built environment	Construction durable - bâtiment  <i>Remark:</i> Recommendation not standard
<b>Installation</b>				
<b>Maintenance</b>				

#### 4.5 Safety in use

	Standards guidelines	&	Title	Remarks
<b>Components</b>				
<i>Modules</i>				
<i>Inverters</i>	SN EN 61727:2004		Photovoltaic (PV) systems - Characteristics of the utility interface (IEC 61727:1995)	Description words: Electric mains, Network interfaces, Photovoltaics, Protection devices, Protection of persons, Solar energy
<i>Support structure</i>				
<b>System</b>	SEV 7.12 NIBT (2005) (IEC 60364-7-712)		Electrical installations of buildings. Part 7-712: Requirements for special installations or locations - Solar photovoltaic (PV) power supply systems	

## D6.1.2 Building Codes BIPV in Europe

	Standards guidelines	&	Title	Remarks
	SN EN 61173		Overvoltage protection for photovoltaic (PV) power generating systems - Guide (IEC 61173:1992)	
<b>Installation</b>	SIA 462 SN 505462		Evaluation of the structural safety of the existing works	Evaluation de la sécurité structurale des ouvrages existants
	SIA 465 SN 580465		Safety in construction and installations	Sécurité des ouvrages et des installations  Description words : Buildings, Construction, Design, Planning, Plant, Risk analysis, Safety
	SIA 2018		Checking of the Parasismic safety of existing buildings	Vérification de la sécurité parasismique des bâtiments existants
<b>Maintenance</b>				

## 4.6 Protection against noise

	Standards guidelines	&	Title	Remarks
<b>Components</b>				
<i>Modules</i>				
<i>Inverters</i>				
<i>Support structure</i>				
<b>System</b>				
<b>Installation</b>	181.003/A1 SN EN ISO 140-3/A1		Acoustics - Measurements of soundproofing of buildings and structural components	Acoustique – Mesurage de l'isolement acoustique des immeubles et des éléments de construction
	SIA 181 SN 520181		Protection against noise in building environment	Protection contre le bruit dans le bâtiment
	SIA 331 SN 563331		Windows	<i>Remarks:</i> Protection against noise for PV glasses
<b>Maintenance</b>				

	Standards guidelines	&	Title	Remarks

#### **4.7 Energy, economy and heat retention**

	Standards guidelines	&	Title	Remarks
<b>Components</b>				
<i>Modules</i>				
<i>Inverters</i>				
<i>Support structure</i>				
<b>System</b>	SIA 331 SN 563331		Windows	Remarks: Thermal insulation
	SIA 180 SN 520180		Thermal insulation and humidity protection in the building area	
	SIA 380/1 SN 520380-1		Thermal energy in building environment	L'énergie thermique dans le bâtiment
	SIA 380/4 SN 520380-4		Electrical energy in building environment	L'énergie électrique dans le bâtiment
	SIA 180.207 SN EN 12114		Thermal performance of buildings - Permeability to air of the components and walls of buildings - Testing method in laboratory	Performance thermique de bâtiments - Perméabilité à l'air des composants et parois de bâtiments - Méthode d'essai en laboratoire
<b>Installation</b>				
<b>Maintenance</b>				

## 5 France

### 5.1 Introduction

With the new French feed-in tariff for BIPV, the government would like to allow robust and sustainable growth of the French market on the market segment of BIPV. The strategy is to give a strong impetus to innovation in architectural integration. Thus, photovoltaics could become one construction material that generates electricity and also become commonplace among the companies from the construction industry.

In France, there is practically no specific regulation concerning the Building Integrated Photovoltaic installations. It means that the photovoltaic modules can not be considered as a glass product.

For a technical assessment the building products are divided into two categories: usual (concrete, glass products) and unusual (innovative products). BIPV systems are defined under the category unusual. Furthermore PV elements can be categorised as independent or integrated, depending on the way of mounting and their functionality. An independent or add-on element is not considered to be a building component. An integrated PV element is part of the building envelope and is a building component. For BIPV there are the following codes and assessments applicable:

1. DTU (Documents Techniques Unifiés, Unified codes of practice): The DTU's relevant to roof and façades are applicable for BIPV;
2. ATEX, technical assessment of an experiment: Especially for innovative products;
3. NF, Norme Francaise.

The products which are used for public building construction are subjected to a technical approbation called "avis technique" delivered by the CSTB (Centre Scientifique et Technique du bâtiment).

As non-traditional facade components they are subject to Technical Assessments given in France by a commission:

- Specialised group n°2 (constructions, facades and lightweight partition) if they are lightweight elements
- Specialised group n°5 (roofing, covering, water tightness) if they are roofing elements
- Specialised group n°7 (supplementary insulation and waterproofing products and systems for external walls) if they are built-up cladding elements.

However, as photovoltaic module integration is an innovative technique, a preliminary procedure is recommended: ATEX procedure (Technical Assessment of an Experiment). This procedure is aimed at easing the first projects applying a new technique. Many ATEX concern the use of glass in the building.

After controls of some installations, this procedure facilitates the realization of the first operations. It is also delivered by the CSTB.

**D6.1.2 Building Codes BIPV in Europe**

For other buildings (private ones), the BIPV is subjected to administrative and lawful conditions which are valid for construction and electric installation. The French standards approved by AFNOR must also be respected.

To introduce a building product on the market in France is it needed to have a CE + RCI mark.

The latter stands for:

- R: responsibility of actors
- C: covers
- I: insurance's

According to the French regulation, integrated modules, as building components are under ten-year warranty while add-on/independent modules, as equipment, are only subject to an either one or two-year warranty.

## 5.2 Mechanical resistance and stability

	Standards & guidelines	Title	Remarks
<b>Components</b>			
<i>Modules</i>	NF C57-100	Transformation directe de l'énergie solaire en énergie électrique. Modules photovoltaïques pour applications terrestres - Norme générique	English translation : Direct transformation of solar energy into electrical energy. Terrestrial photovoltaic modules
	NF C57-105, NF EN 61215	Modules photovoltaïques (PV) au silicium cristallin pour application terrestre. Qualification de la conception et homologation	English translation: Crystalline silicon terrestrial photovoltaic (PV) modules - Design qualification and type approval
	NF C57-107, NF EN 61721	Sensibilité d'un module photovoltaïque au dommage par impact accidentel (résistance à l'essai d'impact).	English translation: Susceptibility of a photovoltaic (PV) module to accidental impact damage (resistance to impact test).
	NF C57-109, NF EN 61646	Modules photovoltaïques (PV) en couches minces pour application terrestre. Qualification de la conception et homologation	English translation: Thin-film terrestrial photovoltaic (PV) modules - Design qualification and type approval
<i>Inverters</i>			
<i>Support structure</i>	See system		

**D6.1.2 Building Codes BIPV in Europe**

	<b>Standards &amp; guidelines</b>	<b>Title</b>	<b>Remarks</b>
<b>System</b>	NF P06-113-1, NF EN 1991-1-3	Eurocode 1. Actions sur les structures. Partie 1-3 : actions générales - Charges de neige	English translation : Eurocode 1 - Actions on structures - Part 1-3 : general actions - Snow loads
	NF P06-114-1, NF EN 1991-1-4	Eurocode 1 : actions sur les structures. Partie 1-4 : actions générales - Actions du vent	English translation : Eurocode 1 : actions on structures - Part 1-4 : general actions - Wind actions
	NF P22-311-1, NF EN 1993-1-1	Eurocode 3. Calcul des structures en acier. Partie 1-1 : règles générales et règles pour les bâtiments	English translation : Eurocode 3 : design of steel structures - Part 1-1 : general rules and rules for buildings
	NF P21-711-1, NF EN 1995-1-1	Eurocode 5. Conception et calcul des structures en bois. Partie 1-1 : généralités - Règles communes et règles pour les bâtiments	English translation : Eurocode 5 - Design of timber structures - Part 1-1 : general - Common rules and rules for buildings
	NF P06-030-1, NF EN 1998-1	Eurocode 8. Calcul des structures pour leur résistance aux séismes. Partie 1 : règles générales, actions sismiques et règles pour les bâtiments	English translation : Eurocode 8 - Design of structures for earthquake resistance - Part 1 : general rules, seismic actions and rules for buildings
	NF P22-151 to 155, NF EN 1999-1-1 to 5	Eurocode 9. Calcul des structures en aluminium.	English translation : Eurocode 9 - Design of aluminium structures -
	ISO 7599	Anodizing of aluminium and its alloys; General specifications for anodic oxide coatings on aluminium	
	NF P08-302	Murs extérieurs des bâtiments - Résistance aux chocs - Méthodes d'essais et critères	English translation : External walls of buildings. Impact resistance. Test methods and criteria
	NF P01-012	Dimensions des garde-corps - Règles de sécurité relatives aux dimensions des garde-corps et rampes d'escalier	English translation : Dimensions of rails. Safety regulations relating to the dimensions of ground rails and staircase hand-rails
<b>Installation</b>			

**D6.1.2 Building Codes BIPV in Europe**

	<b>Standards &amp; guidelines</b>	<b>Title</b>	<b>Remarks</b>
<b>Maintenance</b>	NF P06-111-1, NF EN 1991-1-1	Eurocode 1. Actions sur les structures. Partie 1-1 : actions générales - Poids volumiques, poids propres, charges d'exploitation des bâtiments	English translation : Eurocode 1 - Actions on structures - Part 1-1 : general actions - Densities, self weight, imposed loads for buildings

**5.3 Safety in case of fire**

	<b>Standards &amp; guidelines</b>	<b>Title</b>	<b>Remarks</b>
<b>Components</b>			
<i>Modules</i>	See system		
<i>Inverters</i>			
<i>Support structure</i>	See system		
<b>System</b>	BP X70-200	Guide pour l'amélioration de la protection incendie des bâtiments d'habitation existants - Organisation et démarche	English translation: Draft guide for improvement of the fire protection of existing dwelling houses - Organisation and methodology
	NF P92-525, NF EN 13238	Essais de réaction au feu des produits de construction - Mode opératoire du conditionnement et règles générales de sélection des substrats	English translation: Reaction to fire tests for building products - Conditioning procedures and general rules for selection of substrates
	NF P92-800-1, NF EN 13501-1 NF P92-800-2, NF EN 13501-2	Classement au feu des produits et éléments de construction Partie 1 : classement à partir des données d'essais de réaction au feu Partie 2 : classement à partir des données d'essais de résistance au feu à l'exclusion des produits utilisés dans les systèmes de ventilation	English translation: Fire classification of construction products and building elements Part 1 : classification using test data from reaction to fire tests Part 2 : classification using data from fire resistance tests, excluding ventilation services
	NF P92-101-1, NF EN 1363-1 NF P92-101-2, NF EN 1363-2	Essais de résistance au feu Partie 1 : exigences générales Partie 2 : modes opératoires de substitution ou additionnels	English translation: Fire resistance tests Part 1 : general requirements. Part 2 : alternative and additional procedures.

## D6.1.2 Building Codes BIPV in Europe

	<b>Standards &amp; guidelines</b>	<b>Title</b>	<b>Remarks</b>
	NF P92-120-1, NF EN 1365-1 NF P92-120-2, NF EN 1365-2 NF P92-120-5, NF EN 1365-5	Essais de résistance au feu des éléments porteurs. Partie 1 : murs Partie 2 : planchers et toitures Partie 5 : balcons et passerelles	English translation: Fire resistance tests for load bearing elements Part 1 : walls Part 2 : floors and roofs Part 5 : balconies and walkways
	NF P92-527, NF EN 13823	Essais de réaction au feu des produits de construction. Produits de construction à l'exclusion des revêtements de sol exposés à une sollicitation thermique provoquée par un objet isolé en feu	English translation: Reaction to fire tests for building products - Building products excluding floorings exposed to the thermal attack by a single burning item
	NF P92-520, NF EN ISO 1182	Essais de réaction au feu des produits de construction. Essai d'incombustibilité	English translation: Reaction to fire tests for building products - Non-combustibility test
	NF P92-522, NF EN ISO 11925-2	Essais de réaction au feu. Allumabilité des produits de bâtiment soumis à l'incidence directe de la flamme. Partie 2 : essai à l'aide d'une source à flamme unique	English translation: Reaction to fire tests - Ignitability of building products subjected to direct impingement of flame - Part 2 : single-flame source test
	NF P92-501	Sécurité contre l'incendie. Bâtiment - Essais de réaction au feu des matériaux. Essai par rayonnement applicable aux matériaux rigides ou rendus tels (matériaux de revêtement collés) de toute épaisseur et aux matériaux souples d'épaisseur supérieure à 5 mm.	English translation: Safety against fire. Building materials. Reaction to fire tests. Radiation test used for rigid materials, or for materials on rigid substrates (flooring and finishes) of all thicknesses, and for flexible materials thicker than 5 mm
	NF P92-503	Sécurité contre l'incendie. Bâtiment - Essais de réaction au feu des matériaux. Essai au brûleur électrique applicable aux matériaux souples.	English translation: Safety against fire. Building materials. Reaction to fire tests. Electrical burner test used for flexible materials
	NF P92-507	Sécurité contre l'incendie. Bâtiment - Matériaux d'aménagement. Classement selon leur réaction au feu	English translation: Fire safety - Building - Interior fitting materials - Classification according to their reaction to fire.

	<b>Standards &amp; guidelines</b>	<b>Title</b>	<b>Remarks</b>
	NF P92-511	Bâtiment - Essais de réaction au feu des matériaux. (annexe aux normes de méthodes d'essais) - Détermination des essais à réaliser suivant la nature et l'utilisation des matériaux - Supports-types - Modèles de fiches d'information	English translation: Safety against fire. Building materials. Reaction to fire tests (annex to the test methods). Determination of the tests to be selected according to the nature and utilization of the materials. Standard backing. Information forms models
	NF P92-512	Sécurité contre l'incendie - Bâtiment - Essais de réaction au feu des matériaux - Détermination de la durabilité des classements en réaction au feu des matériaux - Essais	English translation: Safety against fire. Building. Reaction to fire tests. Determination of the durability of the fire reaction classification of materials. Tests
	XP P92-160, XP ENV 1187	Méthodes d'essai pour l'exposition des toitures à un feu extérieur	English translation: Test methods for external fire exposure to roofs
<b>Installation</b>			
<b>Maintenance</b>			

#### **5.4 Hygiene, health and the environment**

	<b>Standards &amp; guidelines</b>	<b>Title</b>	<b>Remarks</b>
<b>Components</b>			
<i>Modules</i>	NF C15-100	Installations électriques à basse tension (complétée avec la mise à jour de Juin 2005)	English translation: Low-voltage electrical installations (completed with update of June 2005).
	NF C57-105, NF EN 61215	Modules photovoltaïques (PV) au silicium cristallin pour application terrestre. Qualification de la conception et homologation	English translation: Crystalline silicon terrestrial photovoltaic (PV) modules - Design qualification and type approval
	NF C57-106, NF EN 61701	Essai de corrosion au brouillard salin des modules photovoltaïques (PV).	English translation: Salt mist corrosion testing of photovoltaic (PV) modules

## D6.1.2 Building Codes BIPV in Europe

	<b>Standards &amp; guidelines</b>	<b>Title</b>	<b>Remarks</b>
	NF C57-107, NF EN 61721	Sensibilité d'un module photovoltaïque au dommage par impact accidentel (résistance à l'essai d'impact).	English translation: Susceptibility of a photovoltaic (PV) module to accidental impact damage (resistance to impact test).
	NF C57-109, NF EN 61646	Modules photovoltaïques (PV) en couches minces pour application terrestre. Qualification de la conception et homologation	English translation: Thin-film terrestrial photovoltaic (PV) modules - Design qualification and type approval
<i>Inverters</i>	NF C15-100	Installations électriques à basse tension (complétée avec la mise à jour de Juin 2005)	English translation: Low-voltage electrical installations (completed with update of June 2005).
	NF C57-337, NF EN 62093	Composants BOS des systèmes photovoltaïques. Qualification et essais d'environnement	English translation: Balance-of system components for photovoltaic systems - Design qualification natural environments
	DIN V VDE V 0126-1-1	Automatic disconnection device between a generator and the public low-voltage grid	
<i>Support structure</i>	NF P24-351	Menuiserie métallique. Fenêtres, façades rideaux, semi-rideaux, panneaux à ossature métallique. Protection contre la corrosion et préservation des états de surface.	English translation : Metal joinery. Windows, curtain walling, metal frame panels. Protection against corrosion and conservation of surface conditions.
<b>System</b>	NF C15-100	Installations électriques à basse tension (complétée avec la mise à jour de Juin 2005)	English translation: Low-voltage electrical installations (completed with update of June 2005).
	NF C57-331, NF EN 61173	Protection contre les surtensions des systèmes photovoltaïques (PV) de production d'énergie - Guide	English translation: Overvoltage protection for photovoltaic (pv) power generating systems. Guide
	NF C57-337, NF EN 62093	Composants BOS des systèmes photovoltaïques. Qualification et essais d'environnement	English translation: Balance-of system components for photovoltaic systems - Design qualification natural environments

**D6.1.2 Building Codes BIPV in Europe**

	<b>Standards &amp; guidelines</b>	<b>Title</b>	<b>Remarks</b>
	NF P24-351	Menuiserie métallique. Fenêtres, façades rideaux, semi-rideaux, panneaux à ossature métallique. Protection contre la corrosion et préservation des états de surface.	English translation : Metal joinery. Windows, curtain walling, metal frame panels. Protection against corrosion and conservation of surface conditions.
<b>Installation</b>			
<b>Maintenance</b>	XP P28-002-3	DTU 33.1 - Travaux de bâtiment. Façades rideaux, façades semi-rideaux, façades panneaux. Partie 3 : annexe informative : entretien - Maintenance	English translation : DTU 33.1 - Building construction work - Curtain-walling - Part 3 : informative annex : upkeep - Maintenance

**5.5 Safety in use**

	<b>Standards &amp; guidelines</b>	<b>Title</b>	<b>Remarks</b>
<b>Components</b>			
<i>Modules</i>	NF C15-100	Installations électriques à basse tension (complétée avec la mise à jour de Juin 2005)	English translation: Low-voltage electrical installations (completed with update of June 2005).
<i>Inverters</i>	NF C15-100	Installations électriques à basse tension (complétée avec la mise à jour de Juin 2005)	English translation: Low-voltage electrical installations (completed with update of June 2005).
	DIN V VDE V 0126-1-1	Automatic disconnection device between a generator and the public low-voltage grid	
	DIN EN 61000-3-2, VDE 0838-2	Electromagnetic compatibility (EMC) - Part 3-2: Limits - Limits for harmonic current emissions (equipment input current 16 A per phase)	
<i>Support structure</i>			
<b>System</b>	NF C15-100	Installations électriques à basse tension (complétée avec la mise à jour de Juin 2005)	English translation: Low-voltage electrical installations (completed with update of June 2005).
<b>Installation</b>			

	Standards & guidelines	Title	Remarks
<b>Maintenance</b>			

### 5.6 Protection against noise

	Standards & guidelines	Title	Remarks
<b>Components</b>			
<i>Modules</i>			
<i>Inverters</i>			
<i>Support structure</i>			
<b>System</b>	NF S31-010	Acoustique - Caractérisation et mesurage des bruits de l'environnement - Méthodes particulières de mesurage.	Acoustics. Environmental noise characterization and measurement. Special measuring methods
	NF S31-057	Acoustique - Vérification de la qualité acoustique des bâtiments	English translation: Acoustics. Verification of the acoustic quality of buildings
<b>Installation</b>			
<b>Maintenance</b>			

### 5.7 Energy, economy and heat retention

	Standards & guidelines	Title	Remarks
<b>Components</b>			
<i>Modules</i>			
<i>Inverters</i>			
<i>Support structure</i>			
<b>System</b>	RT 2005 Th-C, Th-E, Th-U	Réglementation thermique 2005	English translation : Thermal regulations 2005

	<b>Standards &amp; guidelines</b>	<b>Title</b>	<b>Remarks</b>
<b>Installation</b>			
<b>Maintenance</b>			

## 6 Austria

### 6.1 Introduction

The Austrian technical admittance ÖTZ (Österreichische technische Zulassungen) for a building element will, in dependence of the respective legal federal regulations, be issued by the service of the federal government. However, in Austria in accordance with the building codes, admittance is needed if there is a specific standard operative on this element or if there is a matter of direct danger to the human health or safety. In the opinion of the Österreichisches Institut für Bau-technik, a PV roof or PV facade needs no admittance. This opinion is checked at the federal authorities.

Austria has per federal state a 'Bauordnung' and these building regulations are not based on a paragon, like in Germany or in the Netherlands. This means that the building regulations are mutually different. The judgment of a building element is dependent on the application. Furthermore, every federal state will do it on their own way, based on their own regulations. For example in one state roofing has to be proven resistant against fire spread by wind, in the other, it has not. In this report the Bauordnung of Vienna will be used as an example.

A section of the building regulations of Vienna discusses the general requirements of a construction. These requirements hardly differ of the German demands: every building construction has to comply with 'best practices'. The building materials and building components have to meet the valid regulations and have to be practicable. Practicable is a building component or material if it complies the requirements at constructive safety, fire resistance, hygiene, health, environmental protection, utility, noise protection and thermal insulation.

The government of the state has the possibility to determine these requirements with regulations, classifications and performance levels in accordance with the Ö-Normen or other accepted codes like the European standards. In the last case, one have to take into account the climatically circumstances.

The proof, that to be used building materials, building parts or the way of building corresponds with the best practice comes under the landowner or a person with the authorization of the landowner. If the building materials, building parts or the way of building is allowed by the regulations of the national government or the Magistrates or they are marked with the CE-sign no proof has to be given.

The city council has the competence to admit building materials, building parts or the way of building which are not yet certified in accordance with building codes. The use of these is limited by time. During a period of maximum 4 years these building materials, building parts or the way of building are allowed. However the admittance has no legal responsibility. By regulations of the national government also building materials, components or constructions without an official argumentation of them accordance with the building standards, can be applied if these materials or constructions, based on long experiences, comply with the best practice.

In several Austrian Bauverordnungen concrete values are mentioned for the thermal insulation of building parts. However, the national government has the authority to heighten the values, in accordance with the state of technique. Besides the technical requirements, the influence on the townscape, in a aesthetic sense, will also be on consequence. In Austria, agreements between principal and building contractor are arranged in accordance with a

number of codes (Ö-Norm 2110 t/m 2113). In these codes are described the expectations of each other and the procedures have to be taken if the agreements are not observed.

## 6.2 Mechanical resistance and stability

	Standards & guidelines	Title	Remarks
<b>Components</b>			
<i>Modules</i>	ÖNORM E 2750	Photovoltaic power-systems - Erection and safety requirements	
	ÖNORM EN 61215	Crystalline silicon terrestrial photovoltaic (PV) modules - Design qualification and type approval (IEC 61215:2005)	
	ÖNORM B 3716:2006	Glass in building - Structural glass construction -	Part 1 Fundamentals of using glass in buildings including fire protection
		Glass in building - Structural glass construction	Part 2 Linear glazings
		Glass in building - Structural glass construction	Part 3 Fall protection glazings
		Glass in building - Structural glass construction	Part 4 Glazings for promenade and wheel loads of vehicles
<i>Inverters</i>			
<i>Support structure</i>			
	Ö-Norm B 3350	Tragende Wände	
	Ö-Norm B 3355	Feuchtigkeit Wände	
	Ö-Norm B 4012	Load estimations in civil engineering - differential impacts - useful loads <i>Belastungsannahmen im Bauwesen</i>	
	Ö-Norm B 4013	Load estimations in civil engineering - snow and ice loads <i>Belastungsannahmen im Bauwesen</i>	
	Ö-Norm B 4014	Load estimations in civil engineering - static wind loads <i>Belastungsannahmen im Bauwesen, Statische Windkräfte</i>	
<b>Installation</b>			
<b>Maintenance</b>			

**D6.1.2 Building Codes BIPV in Europe**

	Standards & guidelines	Title	Remarks

**6.3 Safety in case of fire**

	Standards & guidelines	Title	Remarks
<b>Components</b>			
<i>Modules</i>	ÖNORM EN 61215	Crystalline silicon terrestrial photovoltaic (PV) modules – Design qualification and type approval	Requirements for the design qualification and type approval of terrestrial photovoltaic modules suitable for long-term operation in general open air climates as defined in IEC 60721-2-1, applies to crystalline silicon.
<i>Inverters</i>			
<i>Support structure</i>			
<b>System</b>	Ö-Norm B3800	Part 1: Behaviour of building materials and components in fire; building materials: requirements and tests. Brandverhalten von Baustoffen und Bauteilen; Baustoffe: Anforderungen und Prüfungen	
		Part 2: Behaviour of building materials and components in fire; building materials: definitions, requirements and tests. <i>Brandverhalten von Baustoffen und Bauteilen; Baustoffe: Begriffsbestimmungen, Anforderungen und Prüfungen</i>	

	Standards & guidelines	Title	Remarks
		Part 3: Behaviour of building materials and components in fire; special building components: definitions, requirements and tests. <i>Brandverhalten von Baustoffen und Bauteilen; Sonderbauteile: Begriffsbestimmungen, Anforderungen und Prüfungen</i>	
<b>Installation</b>			
<b>Maintenance</b>			

#### **6.4 Hygiene, health and the environment**

	Standards & guidelines	Title	Remarks
<b>Components</b>			
<i>Modules</i>			
<i>Inverters</i>			
<i>Support structure</i>			
<b>System</b>			
	EN 86	Testing of windows. Water tightness under static pressure	
	Ö-Norm B3646	6	Waterproofness
<b>Installation</b>			
<b>Maintenance</b>			

## 6.5 Safety in use

	<b>Standards &amp; guidelines</b>	<b>Title</b>	<b>Remarks</b>
<b>Components</b>			
<i>Modules</i>	ÖNORM EN 61215	Crystalline silicon terrestrial photovoltaic (PV) modules – Design qualification and type approval	Requirements for the design qualification and type approval of terrestrial photovoltaic modules suitable for long-term operation in general open air climates as defined in IEC 60721-2-1, applies to crystalline silicon.
<i>Inverters</i>	ÖVE-A/EN 60529/1991	Degrees of protection provided by enclosures (IP code)	(IEC 60529:1989 + A1:1999)
	ÖNORM EN 61727	Photovoltaic (PV) systems - Characteristics of the utility interface	This International Standard applies to utility-interconnected photovoltaic (PV) power systems operating in parallel with the utility and utilizing static (solid-state) non-islanding inverters for the conversion of DC to AC.
<i>Support structure</i>			
<b>System</b>	Ö-Norm E 2980	Lightning protection systems - Design of components and assembly measurements - installation examples	
	Ö-Norm M 7700	Solar energy - designation and definition	
	ÖVE-A/EN 60529/1991	Protection types through casing (IP code)	
	ÖVE-B/EN 60555	Part 2: Feedback in supply grids caused by household goods and other similar electrical equipment; part 2: harmonic oscillations	
	ÖVE-E 5	Part 1: Operation of heavy current systems - basic regulations	
	ÖVE-E 49	Lightning protection systems	

## D6.1.2 Building Codes BIPV in Europe

	Standards & guidelines	Title	Remarks
	ÖVE-EN 1	Part 1: Installation of heavy current systems with rated voltages up to ~1000 V and ... 1500 V; part 1: Terminology and protection against electric shock (safety measures)	
	ÖVE-EN 1	Part 3: Installation of heavy current systems with rated voltages up to ~1000 V and ... 1500 V; part 3: composition, configuration and installation of wiring and cables	
	ÖVE-FE/EN 55014	Limiting values and measurement procedure for radio disturbance through electrical household appliances, electrical hand tools and similar electrical appliances	
	ÖVE-SN 60	Part 1: Surge arrester for grids with rated voltages of up to ~1000 V and ... 1500 V; general regulations	
	EN 50110: 1998/C1:2001 en	Operation of electrical installations (National Annexes)	
<b>Installation</b>			
<b>Maintenance</b>			

## 6.6 Protection against noise

	Standards & guidelines	Title	Remarks
<b>Components</b>			
<i>Modules</i>			
<i>Inverters</i>			
<i>Support structure</i>			

	<b>Standards &amp; guidelines</b>	<b>Title</b>	<b>Remarks</b>
<b>System</b>	Ö-Norm B 8115	Sound insulation in building construction and architectural acoustics; concept and units <i>Schallschutz und Raumakustik im Hochbau; Begriffe und Einheiten</i>	
	Ö-Norm B 8115	Sound insulation in building construction and architectural acoustics; requirements for sound insulation <i>Schallschutz und Raumakustik im Hochbau; Anforderungen an den Schallschutz</i>	
	Ö-Norm B 8115	Sound insulation in building construction and architectural acoustics; Measures to come towards the requirements <i>Schallschutz und Raumakustik im Hochbau; Maßnahmen zur Erfüllung der schalltechnischen Anforderungen (in Vorbereitung)</i>	
	Ö-Norm S 5100	Building acoustic measurements. Measurements of the air sound insulation of windows and exterior walls of buildings <i>Bauakustische Messungen; Messung des Luftschallschutzes von Fenstern und Außenwänden an Gebäuden</i>	
<b>Installation</b>			
<b>Maintenance</b>			

### **6.7 Energy, economy and heat retention**

	<b>Standards &amp; guidelines</b>	<b>Title</b>	<b>Remarks</b>
<b>Components</b>			
<i>Modules</i>			
<i>Inverters</i>			
<i>Support structure</i>			
<b>System</b>	Ö-Norm 8110	Thermal insulation in buildings Wärmeschutz im Hochbau	
<b>Installation</b>			
<b>Maintenance</b>			

## 7 Italy

### 7.1 Introduction

The revised Italian feed-in tariff (Conto Energia, February 2007) is aimed to strongly increase the amount of electricity generated by means of PV in Italy. Most of the new installations are expected to be grid-connected Building Applied or Building Integrated ones.

In Italy, however, no specific regulation or standard concerning Building Integrated PV installations so far exist. If a PV element is integrated into the building's envelope it should be treated as a building element and ideally fulfil all requirements contained in the 'Norme tecniche per le costruzioni (ex Testo Unico)' (Technical Norms for Constructions, former Unified Text) text published on the Italian Official Journal (Gazzetta Ufficiale) on the 23rd of September 2005. This text contains the whole set of Italian norms relative to the planning and realisation of building manufactures.

Also in Italy several guides for installing PV systems exist. However, for grid-connected systems all relevant norms can be found in the "Guida CEI 82-25, Guida alla realizzazione di sistemi di generazione fotovoltaica collegati alle reti elettriche di Media e Bassa Tensione" (Guide for the realization of photovoltaic systems connected to Medium and Low tension electric-grids). The most relevant ones are listed in the tables below.

List of abbreviations used in the text:

CEI = Comitato Elettotecnico Italiano

Note: CEI EN is not a Committee but a standard of Italian Committee which comes from an European Norm (EN);

CENELEC = European Electric Committee

IEC = International Electric Committee

UNI = Ente Nazionale Italiano di Unificazione

### 7.2 Mechanical resistance and stability

	Standards & guidelines	Title	Remarks
<b>Components</b>			
<i>Modules</i>	CEI EN 61215 (CEI 82-8)	Crystalline silicon terrestrial photovoltaic (PV) modules – Design qualification and type approval	
	CEI EN 61646 (CEI 82-12)	Thin-film terrestrial photovoltaic (PV) modules – Design qualification and type approval	

**D6.1.2 Building Codes BIPV in Europe**

	CEI EN 61701	Salt mist corrosion testing of photovoltaic (PV) modules	
	CEI EN 50380	Datasheet and nameplate information for photovoltaic modules	
	CEI EN 61730-1	Photovoltaic (PV) module safety qualification. Part 1: Requirements for construction	
	CEI EN 61730-2	Photovoltaic (PV) module safety qualification - Part 2: Requirements for testing	
<i>Inverters</i>	CEI EN 62093 (CEI 82-24)	Balance-of-system components for photovoltaic systems - Design qualification natural environments	Componenti di sistemi fotovoltaici – moduli esclusi (BOS) Qualifica di progetto in condizioni ambientali naturali
<i>Support structure</i>	CEI EN 62093 (CEI 82-24)	Balance-of-system components for photovoltaic systems - Design qualification natural environments	
<b>System</b>	CEI EN 61721	Susceptibility of a photovoltaic (PV) module to accidental impact damage (resistance to impact test)	
<b>Installation</b>	Law 1086/71	Standards regulating building structures in armored cement, pre-compressed and normal, and with a metal structure.	Norme per la disciplina delle opere di conglomerato cementizio armato, normale e precompresso, ed a struttura metallica
	Law 64/74	Provisions for building with special requirements for seismic zones	Provvedimenti per le costruzioni con particolari prescrizioni per le zone sismiche)
	D.M. 9/1/96 (ministerial decree 9/1/96)	Technical standards for the computation, execution, and technical approval of structures in armored cement, pre-compressed and normal, and with a metal structure.	Norme tecniche per il calcolo, l'esecuzione ed il collaudo delle strutture in c.a. normale e precompresso e per le strutture metalliche.

**D6.1.2 Building Codes BIPV in Europe**

	Ministerial memorandum 15/10/96 n. 252	Instructions for the applications of the norms contained in D.M. 9/1/96;	Istruzioni per l'applicazione delle norme di cui al D.M. 9/1/96;
	D.M. 16/1/96 (ministerial decree 16/1/96)	Technical standards relative to general criteria for the verification of safety in the building sector, loads and overloading;	Norme tecniche relative ai "criteri generali per la verifica di sicurezza delle costruzioni e dei carichi e sovraccarichi";
	Ministerial memorandum 4/7/96 n. 156	Instructions for the applications of the norms contained in D.M. 16/1/96;	Istruzioni per l'applicazione delle norme di cui al D.M. 16/1/96;
	D.M. 16/1/96 (ministerial decree 16/1/96)	Technical standards for building in seismic zones	Norme tecniche per le costruzioni in zona sismica
	Decree 3274 (Italian Official Journal, G.U. 8/5/03).	First elements concerning general criteria for the seismic classification of national territory and technical norms for building in earthquake zones	Primi elementi in materia di criteri generali per la classificazione sismica del territorio nazionale e di normative tecniche per le costruzioni in zona sismica
	D.M. 14/9/05 (ministerial decree 14/9/05)	Technical Norms for Constructions, former Unified Text	Testo Unico Norme Tecniche per le Costruzioni
	UNI ENV 1991-1	Eurocode 1 - Actions on structures – Part 1: computational basis	Eurocodice 1 -Basi di calcolo ed azioni sulle strutture – Parte 1: basi di calcolo
	UNI ENV 1991-2-1	Eurocode 1 – Actions on structures – Part 2-1: general actions – Volumetric mass, inherent weight and composite loads	Eurocodice 1 – Basi di calcolo ed azioni sulle strutture – Parte 2-1: Azioni sulle strutture – Massa volumica, pesi propri e carichi composti
	UNI ENV 1991-2-3	Eurocode 1 – Actions on structures – Part 2-3: general actions – Snow loads	Eurocodice 1 – Basi di calcolo ed azioni sulle strutture – Parte 2-3: Azioni sulle strutture – Carichi da neve

**D6.1.2 Building Codes BIPV in Europe**

	UNI ENV 1991-2-4	Eurocode 1 – Action on structures – Part 2-4: general actions – Wind actions	Eurocodice 1 – Basi di calcolo ed azioni sulle strutture – Parte 2-4: Azioni sulle strutture – Azioni del vento
	UNI ENV 1991-2-5	Eurocode 1 – Action on structures – Part 2-5: general actions – thermal actions	Eurocodice 1 – Basi di calcolo ed azioni sulle strutture – Parte 2-5: Azioni sulle strutture – Azioni termiche
<b>Maintenance</b>			

**7.3 Safety in case of fire**

	Standards & guidelines	Title	Remarks
<b>Components</b>			
<i>Modules</i>			
<i>Inverters</i>			
<i>Support structure</i>			
<b>System</b>	CEI EN 62305 (CEI 81-10)	Protection against lightnings	Protezione contro i fulmini
	CEI 81-3	Mean value of number of lighting strikes per year per square kilometre.	Valore medio del numero di fulmini a terra per anno e per kilometro quadrato
<b>Installation</b>			
<b>Maintenance</b>			

**7.4 Hygiene, health and the environment**

	Standards & guidelines	Title	Remarks
<b>Components</b>			
<i>Modules</i>			
<i>Inverters</i>			
<i>Support structure</i>			

**D6.1.2 Building Codes BIPV in Europe**

<b>System</b>	CEI EN 62093 (CEI 82-24)	Componenti di sistemi fotovoltaici – moduli esclusi (BOS) Qualifica di progetto in condizioni ambientali naturali	
<b>Installation</b>			
<b>Maintenance</b>			

**7.5 Safety in use**

	<b>Standards guidelines</b>	<b>&amp; Title</b>	<b>Remarks</b>
<b>Components</b>			
	CEI 20-19  CEI 20-20	Rubber isolated cables with nominal tension not above 450/750 V;  Polyvinyl Chloride isolated cables with nominal tension not above 450/750 V;	Cavi isolati con gomma con tensione nominale non superiore a 450/750 V;  Cavi isolati con polivinilcloruro con con tensione nominale non superiore a 450/750 V;
	CEI 11-27	Activity on electric plants.	Lavori su impianti elettrici
	CEI 64-8	Electrical plants employing electrical nominal tension not above AC-1000 V and DC-1500 V.	Impianti elettrici utilizzatori a tensione nominale non superiore a 1000 V in corrente alternata e a 1500 V in corrente continua
	CEI 64-12	Guide for the execution of ground-plants in the residential and tertiary sector buildings	Guida per l'esecuzione dell'impianto di terra negli edifici per uso residenziale e terziario
	CEI 64-14	Guide for the verification of electrical end-user plants	Guida alla verifica degli impianti elettrici utilizzatori
	IEC/TS 60479-1	Effects of current on human beings and livestock – Part 1: General aspects	

**D6.1.2 Building Codes BIPV in Europe**

	<b>Standards &amp; guidelines</b>	<b>Title</b>	<b>Remarks</b>
	IEC 60364-7-712	Electrical installations of buildings – Part 7-712: Requirements for special installations or locations – Solar photovoltaic (PV) power supply systems	
	CEI EN 60529 CEI 70-1	Level of protection of covers (IP codes)	Gradi di protezione degli involucri (codice IP)
	CEI 20-19  CEI 20-20	Rubber isolated cables with nominal tension not above 450/750 V;  Polyvinyl Chloride isolated cables with nominal tension not above 450/750 V;	Cavi isolati con gomma con tensione nominale non superiore a 450/750 V;  Cavi isolati con polivinilcloruro con con tensione nominale non superiore a 450/750 V;
	CEI 11-27	Activity on electric plants.	Lavori su impianti elettrici
<b>System</b>	CEI EN 62305 (CEI 81-10)	Protection against lightning	Protezione contro i fulmini
	CEI 81-3	Mean value of number of lighting strikes per year per square kilometre.	Valore medio del numero di fulmini a terra per anno e per kilometro quadrato
	CEI EN 60439 (CEI 17-13)	Protection devices for low tensions (LT switchboards)	Apparecchiature assiemate di protezione e di manovra per bassa tensione (quadri BT)
<b>Installation</b>	CEI 64-8	Electrical plants employing electrical nominal tension not above AC-1000 V and DC-1500 V.	Impianti elettrici utilizzatori a tensione nominale non superiori a 1000V in corrente alternata e a 1500 V in corrente continua
<b>Maintenance</b>			

**7.6 Protection against noise**

	<b>Standards &amp; guidelines</b>	<b>Title</b>	<b>Remarks</b>
<b>Components</b>			
<i>Modules</i>			
<i>Inverters</i>			
<i>Support structure</i>			

	Standards & guidelines	Title	Remarks
<b>System</b>			
<b>Installation</b>			
<b>Maintenance</b>			

### **7.7 Energy, economy and heat retention**

	Standards & guidelines	Title	Remarks
<b>Components</b>			
<i>Modules</i>			
<i>Inverters</i>			
<i>Support structure</i>			
<b>System</b>	UNI 10349	Heating and cooling of buildings. Climatic data.	Riscaldamento e raffrescamento degli edifici. Dati climatici.
<b>Installation</b>			
<b>Maintenance</b>			

## 8 Spain

### 8.1 Introduction

The integration of photovoltaics in buildings is becoming a reality also in Spain. Since a few years this application is increasing with new interesting examples. The integration can be made on a wide range of surfaces and applications combining the electricity production with other functions of the building envelope, such as roof and facade integration, sun shading and heat production.

Nevertheless, one of the main barriers for the wide spread of integration of photovoltaics into buildings is a lack of legislation and specific standards for components, installations, connection to the grid, etc. This study helps to analyse the Spanish norms, standards and laws, about building and construction technologies, applicable in the integration of photovoltaic systems in buildings. The aim is to make easy the knowledge of the Spanish legislation about this application. However, and as a general conclusion, the Spanish specific legislation is very scarce at the present time.

### 8.2 Overview of standards and guidelines

#### **Basic regulation on building**

This kind of norms must be observed in Spain. Frequently, these norms contain the specifications about a particular characteristic of the building, its thermal conditions, acoustics, tec. Therefore each norm has a specific scope, but usually there is an indirect connection between two or more standards. This makes too much complex to render and observe all the norms at the same time.

#### **CT-79 “Thermal conditions on buildings**

In this norm, there are two basic groups of conditions, one associated with the thermal loss coefficient of the building, another one with the hygrothermal performance. These conditions are indicated in the articles of the norm, and there is a more detailed explains in the calculus annexes. To justify the fulfillment of the norm, all project must enclose a justify sheet, as the model shown in the norm.

The 2<sup>nd</sup> article, titled “Scope of application”, specify these application criteria:

- The building must be a new construction building, the retrofitted buildings are excluded.
- The building must be a closed building.
- Every housing must fulfil the norm, but in any other use of the construction there is the possibility of not observing the entire norm, if the architect justifies it, and take all the responsibility.
- Also it is possible when, keeping all the interior conditions required in the norm, the building does not increase its energy demand.

#### *Thermal loss coefficient*

To estimate the thermal loss, the NBE-CT-79 defines two different terms, the *K loss coefficient* for each wall or roof, and the *global loss coefficient*  $K_G$ . The second one is a pondered ratio of the thermal loss coefficients of the entire building.

The admissible K values for each building component are shown in Table 1, from the 5<sup>Th</sup> Art:

**Table 1: Admissible K loss coefficient for each building component**

Kind of component		Climatic area, according to Fig.1 (art. 13)			
		V y W	X	Y	Z
<b>Exterior components</b>	Roofs	1.20 (1.40)	1.03(1.20)	0.77(0.90)	0.60(0.70)
	Light facades (= 200 kg/m <sup>2</sup> )	1.03(1.20)	1.03(1.20)	1.03(1.20)	1.03(1.20)
	Heavy facades (>200 kg/m <sup>2</sup> )	1.55(1.80)	1.38(1.60)	1.20(1.40)	1.20(1.40)
	Flats over open area	0.86(1.00)	0.77(0.90)	0.69(0.80)	0.60(0.70)
<b>No heated space partitions</b>	Walls	1.72(2.00)	1.55(1.80)	1.38(1.60)	1.38(1.60)
	Flats and roofs	– (–)	1.20(1.40)	1.03(1.20)	1.03(1.20)

**K maximum values in Kcal /h m<sup>2</sup> (W/m<sup>2</sup> °C)**

The above table gives the K maximum value for each kind of partition. Components with integrated solar systems shall be considerate as exterior components, then shall be choose roofs or wall, and different between light and heavy ones.

The climate areas from Figure 1 are based on the January minimum temperature ratio.

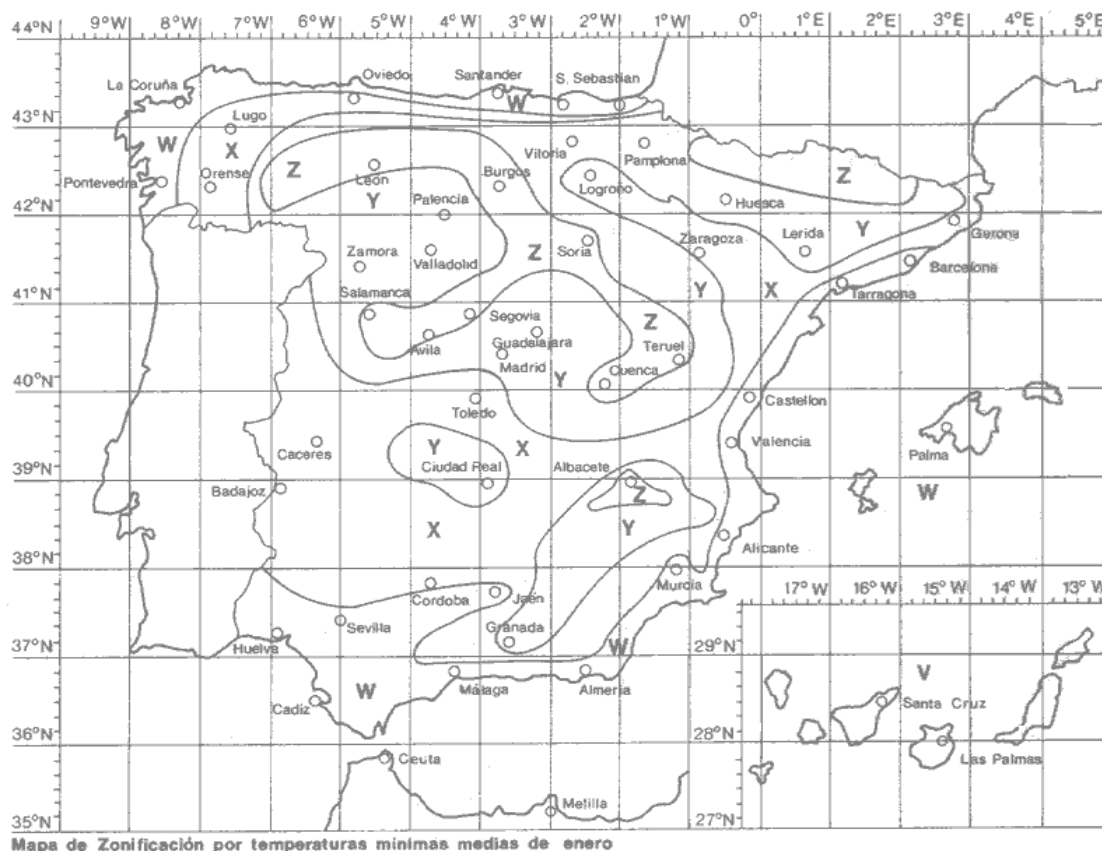

Figure 1. Map indicating the different temperature areas (classified by the averaged minimum temperatures in January).

To limit indirectly the K for each partition there is, in the 10<sup>th</sup> article, a restriction for the rise between superficial and interior temperature of 4°C. This limitation shall not be observed for glazing, doors, windows, skylights; but curtain walls can not be considerate as a glazing only as a wall. To estimate the K value for each partition must be follow the procedure indicated in the annex 2 of the document.

The K coefficient for glazing is not determined in a direct way. When the  $K_G$  is calculated, then the loss through glazing has to be considered; this procedure lets the architect play with the walls and glazing to achieve the fulfillment. The estimation of the  $K_G$  has to be done as shows the justify sheet, at the annex 3.

#### *Hygrothermal building performance*

The 6<sup>th</sup> article explains that the partitions should not have any kind of internal or surface condensation, because it can damage the partition or other near construction elements. In this norm does not appear any other requirement about the hygrothermal performance. Therefore, following the article 6, in the annex number 4 is determined the calculation procedure to know the condensation risk and the different ways to avoid them.

#### **CA-88 “acoustic Conditions on Buildings**

This basic norm explains the acoustic conditions for the buildings. The conditions appear in the norm articles, which are developed in the calculus annexes. To justify the fulfillment of the norm, all the projects should enclose a justifying sheet, as appear in the annex 3 of the norm. The calculation of this justifying sheet must be done as is shown in the calculus annex. Continuously, there are the main articles for the solar integration.

#### *Scope of application*

In the scope of this norm appear the following cases:

- Particular housing
- Public housing (hotels)
- Steward and offices
- Sanitary use (sanatoriums, hospitals)
- Educational use (schools, universities)

Therefore, this article also says that is possible the non-fulfillment of the entire norm, always under the architect responsibility and justify.

#### *Facades*

This article says that the vertical partitions for repose rooms (as bedrooms) have to get an acoustic insulate of 30 dBA<sup>1</sup>. This norm considerate as vertical partitions all of them with a tilt angle above 60 degrees. Other kind of rooms has not a direct limitation for the acoustic insulation. The norm says that the insulation ought to get the level given by a window ‘class a-1’<sup>2</sup>, with a single glazing 5-6 mm thin. This window typology gives an insulate level  $R = 15$  dBA.

#### *Roofs*

---

<sup>1</sup> dBA: adjusted decibel.

<sup>2</sup> This windows classification appears in the CT-79, and is based in the air permeability of the windows. To do the permeability test must be follow the procedure indicated in the norm UNE 7-405-76

This article says that the minimum insulate for airy noise given by the roofs ought to be 45 dBA. Flat roofs also have to give a standard impact noise  $L_N$  under the roof non-higher than 80 dBA, except when the room underneath is not a dwelling.

*Hydraulic pipelines and air ducts*

These pipes will be installed in areas with low acoustic requirements, preferably inside practicable conduits. If necessary, there will be installed antichatter elements. The pipelines will have elements to avoid water hammer.

*CPI "Fire Protection Conditions"*

This norm specifies the fire protection conditions and the emergency exit requirements for buildings. This norm may affect the building design. However, we take only the conditions for roofs and facades.

The most interesting article for fire resistance for constructive elements for integrating solar systems are: *Fire resistance for constructive elements*. This article talks about facades and partition walls of the buildings. This norm does not require a special fire resistance for the whole facade. However, for the joint between facades and buildings partition walls. These walls have a big weight in the fire propagation to neighbouring buildings. Therefore, the facades strip near the joint has a big weight in the fire propagation too.

Whenever the facade joins the partition wall of the building, its fire resistance must be the wall fire resistance<sup>3</sup> divided by two. This condition only affects a strip of the facade. This strip must be one meter wide. However, whenever the facade has an angle smaller than  $135^\circ$ , and the wall joins in this corner, the strip must be at least 2 meters wide. Using overhangs or fins projecting elements can reduce the strip wide, just in case the projecting element is fire resistant.

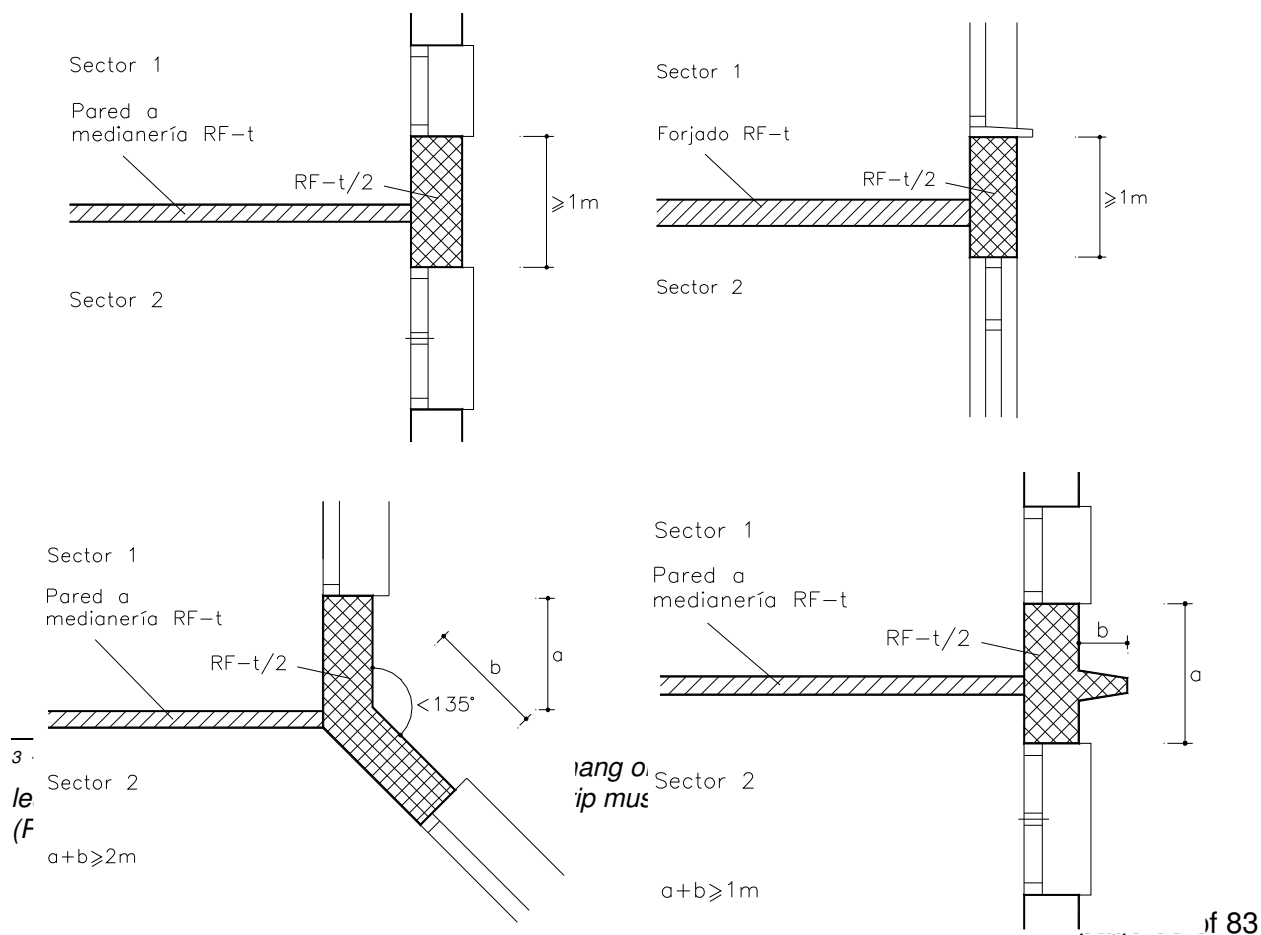

It also happens when the partition wall of the building joins the roof. Then the fire resistance of the roof must be the partition resistance divided by two. This condition affects only a strip of the roof. This strip must be one meter wide. Nevertheless, this strip is not necessary when there is a vertical fire resistant element of 0.60 meters or higher,

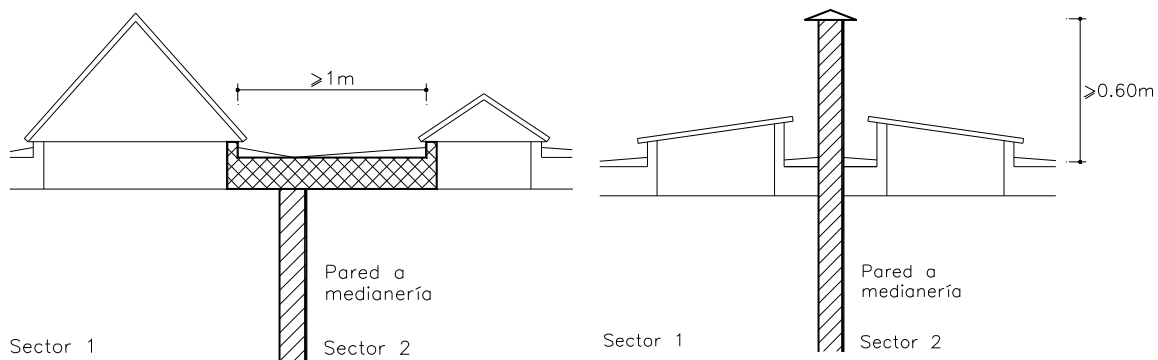

#### **Material conditions**

The second point of this article talks about materials enclosed inside a wall or a roof. When enclosed materials have a fire class less resistant than the asked for covering materials, then the covering materials must be at least 30 min fire resistant (RF-30). This condition is especially important in insulation materials.

#### **QB-90 “Roofs with bituminous materials”**

##### *Scope of application*

This norm must be applied to all the projects with bituminous materials, in new and retrofitted buildings. Although this norm only talks about bituminous materials, we think that it can be interesting for other constructive typologies.

##### *Essential requirements for the roof*

This norm enumerates the following essential requirements for the roofs:

- *Structural resistance and stability.* As is required by the norm NBE-AE “Loads in buildings”
- *Fire security.* As is required by the NBE-CPI “Fire protection conditions”.
- *Healthiness.* The roof must avoid water infiltration inside the building. To fulfill it, the roof must protect the building from the climatic agents, by using a configuration of slopes that allows the water going out. The roof water tightness must be guaranteed for ten years.
- *Security.* The perimeter of the passable flats roofs must have parapets or railings to prevent accidental falls. When the building is 25 m high or less, the parapets must be at least 0.95 m high and the railings must be 1 m high. But if the building is higher than 25 m, then the parapets must be at least 1.05 m high and the railings 1.10 m high. Non-passable roofs must let the access for maintenance works, therefore must have the necessary elements to guarantee the working safety<sup>4</sup>.
- *Protection against noise.* Must be considered the norm NBE-CA “Acoustic conditions”.
- *Energy saving and thermal protection.* As is required by the norm NBE-CT “Thermal conditions”.

<sup>4</sup> Remain that this norm must be applied to roofs with bituminous material, usually flat roofs. Roofs with integrated solar systems can be passable or not, but always accessible for maintenance.

### *Elements fasteners*

The norm says that the fasteners of the elements (like aërials or other installations) that can be on the roof must not cross the waterproof film. These installations should be fastened to walls or bed-plates above the waterproof film.

### *Control of execution*

As the norm says, the construction manager can ask for the following tests:

- *Flooding test.* It consists in flooding the roof till 5 cm under the lowest point of the waterproofing, taking care that the load does not exceed the limit of the roof. The flooding must be during 24 hours.
- *If flooding is not possible,* then the roof will be dropped during 48 hours.

### *Roof use*

When in an existing roof were installed equipment and installations which need a usually maintenance there must be an especial protection for the waterproof films. This protection will avoid damages in the waterproof films.

## **A-88 “Loading on buildings**

This norm specifies all the loads that must be considered in buildings and its structure. These loads must be included in the calculus of all elements (facades and structure) that can be affected by these charges. Here has been followed the same classification used in the norm.

### *Wind Loads*

In buildings with saw tooth shapes (roofs or walls) or with an angle between the facade and the structure, the wind will be studied with the most adverse direction. There will be studied the wind with an angle  $\pm 10^\circ$  from horizontal plane too.

In protected surfaces, under the protection of another element, as happens in sawtooth roofs, the wind coefficient<sup>5</sup> can be reduced a 25%.

### *Gravity loads*

Every structural element, like joist, purling, timber, beam, etc, must be calculated to resist at least the following loads, not at the same time:

- An accurate load of 100 Kg in the most adverse position.
- The proportional load from the normal use.

These loads should be studied especially in the frames of the solar systems.

### *Thermal loads*

The thermal increase for the calculations, if there is not an especial thermal performance of the localization, is:

- For outside metallic frames and direct sun radiation:  $\pm 30^\circ\text{C}$ .
- For other frames:  $\pm 20^\circ\text{C}$ .
- For protected frames:  $\pm 10^\circ\text{C}$ .

## **UNE-EN Standards**

---

<sup>5</sup> This coefficient is estimated as the procedure and the tables shown in the norm. It depends of the climatic area, the high and the shape of the building.

The Spanish Normalization Organism AENOR has to adopt the European Norms (EN) elaborated by the Technical Committees of CEN/CENELEC. The following summarizes the norms related to windows, doors, shutters, blinds and curtain walling for buildings. Most of them classify the building components and their properties but, in general do not establish acceptance levels

**UNE-EN 410:1998.** *Glass in building. Determination of luminous and solar characteristics of glazing.*

This norm specifies the methods for the determination of the luminous and solar properties of glazing for buildings.

**UNE-EN 1096:1998.** *Glass in building. Coated glass. Part 1: Definitions and classification.*

It defines the characteristics, properties and the classification of coated glass for buildings. Includes the testing methods and procedures used for determining the glass durability.

**UNE-EN 1522:1999.** *Windows, doors, shutters and blinds. Bullet resistance. Requirements and classification.*

It specifies the requirements and classification of Windows, doors, shutters and blinds after being tested in accordance to the European Norm EN 1523.

**UNE-EN 1523:1999.** *Windows, doors, shutters and blinds. Bullet resistance. Test method.*

It describes a test method that allows the classification of the bullet resistance of Windows, doors, shutters and blinds.

**UNE-ENV 1627:2000.** *Windows, doors, shutters. Burglar resistance. Requirements and classification*

It specifies the requirements and classification of the burglar resistance properties of windows, doors and shutters.

**UNE-EN 12154:2000.** *Curtain walling. Water tightness. Performance requirements and classification*

It defines the performance requirements and classification of water tightness properties of static or mobile parts of the curtain walling under positive static air pressure.

**UNE-EN 12207:2000.** *Windows and doors. Air permeability. Classification*

It defines the classification of the results of the air permeability test (prEN 1026) for windows and doors.

**UNE-EN 12208:2000.** *Windows and doors. Water tightness. Classification*

It defines the test results for windows and doors tested after the European Norm project PrEN 1027, which describes the test method for water tightness.

**UNE-EN 12210:2000.** *Windows and doors. Resistance to wind load. Classification*

–

## 9 European standards and IEC standards

### 9.1 Introduction

In this chapter an overview is given of the EN and EN-IEC standards which result from the inventory of the reviewed countries. Although not listed at each country's overview, these standards are applicable for all European countries.

### 9.2 Mechanical resistance and stability

	Standards & guidelines	Title	Remarks
<b>Components</b>			
<i>Modules</i>	EN-IEC 61215:2005	Crystalline silicon terrestrial photovoltaic (PV) modules – Design qualification and type approval	Requirements for the design qualification and type approval of terrestrial photovoltaic modules suitable for long-term operation in general open air climates as defined in IEC 60721-2-1, applies to crystalline silicon.
	EN-IEC 61646	Thin-film terrestrial photovoltaic (PV) modules – Design qualification and type approval	Lays down requirements for the type approval in moderate open-air climates. It is written with amorphous silicon technology in mind, but may also be applicable with other thin-film PV module types
	EN-IEC 61701:1999	Salt mist corrosion testing of photovoltaic (PV) modules	Determines the resistance of the module to corrosion from salt mist.
	EN 50380:2003	Datasheet and Nameplate Information for Photovoltaic Modulus	Describes data sheet and nameplate information for non-concentrating photovoltaic modules.
	EN-IEC 61730-1/2 (2007)	Photovoltaic (PV) module safety qualification Part 1: Requirements for construction Part 2: Requirements for testing	Part 1 describes the fundamental construction requirements for photovoltaic (PV) modules in order to provide safe electrical and mechanical operation during their expected lifetime. Part 2 describes the testing requirements for photovoltaic (PV) modules
	EN 572-1:2004	Glass in building - Basic soda lime silicate glass products -	Part 1: Definitions and general physical and mechanical properties
	EN 572-2	Glass in building - Basic soda lime silicate glass products	Part 2: Float glass
	EN 12150-1:2000	Glass in building - Thermally toughened soda lime silicate safety glass	Part 1: Definition and description

## D6.1.2 Building Codes BIPV in Europe

	Standards & guidelines	Title	Remarks
	EN ISO 12543-1:1998	Glass in building - Laminated glass and laminated safety glass -	Part 1: Definitions and description of component parts
	EN ISO 12543-2:1998 + A1:2004	Glass in building - Laminated glass and laminated safety glass -	Part 2: Laminated safety glass
	EN 61345:1998	UV test on photovoltaic (PV) modules	Defines a test which determines the resistance of the module when exposed to ultra-violet (UV) radiation. This test is useful for evaluating the UV resistance of materials such as polymers and protective coatings.
<i>Inverters</i>	EN 62093:2005	Balance-of-system components for photovoltaic systems - Design qualification natural environments	This International Standard establishes requirements for the design qualification of balance-of system (BOS) components used in terrestrial photovoltaic (PV) systems. This standard is suitable for operation in indoor, conditioned or unconditioned; or outdoor in general open-air climates as defined in IEC 60721-2-1, protected or unprotected.
	EN 61000-6-1 EN 61000-6-2 EN 61000-6-3 EN 61000-6-4 EN 61000-3-2 EN 61000-3-3	Electromagnetic compatibility (EMC).	
<i>Support structure</i>	EN-IEC 61215:2005	Crystalline silicon terrestrial photovoltaic (PV) modules – Design qualification and type approval	The constructive aspects of the support structure has to be tested on system level (in combination with the module, fixing parts etc.)
	pr EN 12600 prEN 1288-2 prEN12179-4, EN 77		<i>Facade:</i> Test method (obligatory) ·Structural wind resistance (positive & negative test (prEN12179-4, EN 77) · Impact resistance by Pendulum loading (pr EN 12600) ·Bending strength by pressurised gas (prEN 1288-2)

## D6.1.2 Building Codes BIPV in Europe

	Standards & guidelines	Title	Remarks
	EN 12488:2003 2e Ontw. en	Glass in building - Glazing requirements - Assembly rules	This European Standard applies to all the basic types of external and internal glazing (drawn sheet glass, float, cast glass, wired and non-wired, clear or tinted) in accordance with EN 572 part 1 to 6, as well as to all the derived processed flat glasses (laminated, toughened, coated, solar control and insulating glasses) as defined in appropriate European standards. For certain glass products additional considerations apply. The Standard does not apply to curved (as defined in prEN 13022), corrugated or channel-shaped glasses. This European Standard applies only to edge supported glazing systems which are vertical, or nearly vertical, (i.e. glazing which is no more than 15° from the vertical), in all types of fixed or opening frames. Structural sealant glazing is excluded
	EN 12179:2000 en	Curtain walling - Structural wind resistance - Test Method	method for determining the resistance to wind load of curtain walling, both its fixed and openable parts, under positive and negative static air pressure
	EN 1991-1-4	Eurocode 1: Actions on structures – Wind	Part 1-4: General actions - Wind actions <i>Eurocode 1 will come in charge (including the National Annex) in 2010</i>
	NAD-NVN-ENV 1991-2-4: 1999	Eurocode 1: Basis of design and actions on structures - Part 2-4 - Actions on structures - Wind actions	Part 2-4 - Actions on structures - Wind actions <i>Eurocode 1 will come in charge (including the National Annex) in 2010</i>
	ENV 1991-1-3: 2003	Eurocode 1: Actions on structures – Snow	Part 1-3: General actions - Snow loads <i>Eurocode 1 will come in charge (including the National Annex) in 2010</i>
	ENV 1998 -1-1: 2005	Eurocode 8 - Design of structures for earthquake resistance	Part 1: General rules, seismic actions and rules for buildings <i>Eurocode 8 will come in charge (including the National Annex) in 2010 (check)</i>
	EN 14437:2004 en	Determination of the uplift resistance of installed clay or concrete tiles for roofing - Roof system test method	This European Standard specifies a test method to establish the uplift resistance of installed clay or concrete tiles for roofing, complying to the relevant product standard, EN 490 or EN 1304, which are unfixed or mechanically fixed to the substructure. The test method is applicable to mechanical fixings such as clips, hooks, screws and nails. In case of mechanically fixed tiles, at least every third tile shall be fixed. The method is not applicable for fixed tiles with fixing patterns with less than every third tile fixed. The test method is not applicable to under and over tiles. Examples of these tiles are given in Annex H.

**D6.1.2 Building Codes BIPV in Europe**

	<b>Standards &amp; guidelines</b>	<b>Title</b>	<b>Remarks</b>
	EN 5601 Ontw. en	Hygrothermal performance of buildings	Resistance to wind-driven rain of roof coverings with discontinuously laid small elements - Test method
	EN 14437: 2004 en	Determination of the uplift resistance of installed clay or concrete tiles for roofing	Roof system test method
	EN-IEC 61701:1999	Salt mist corrosion testing of photovoltaic (PV) modules	Determines the resistance of the module to corrosion from salt mist.
	NEN-EN-ISO 6988:1994	Metallic and other non-organic coatings -	Sulfur dioxide test with general condensation of moisture
<b>Installation</b>			
<b>Maintenance</b>			

**9.3 Safety in case of fire**

	<b>Standards &amp; guidelines</b>	<b>Title</b>	<b>Remarks</b>
<b>Components</b>			
<i>Modules</i>	EN-IEC 61215:2005	Crystalline silicon terrestrial photovoltaic (PV) modules – Design qualification and type approval	Requirements for the design qualification and type approval of terrestrial photovoltaic modules suitable for long-term operation in general open air climates as defined in IEC 60721-2-1, applies to crystalline silicon.
	IEC 61646	Thin-film terrestrial photovoltaic (PV) modules – Design qualification and type approval	Lays down requirements for the type approval in moderate open-air climates. It is written with amorphous silicon technology in mind, but may also be applicable with other thin-film PV module types
	EN 61730-2:2007	Photovoltaic (PV) module safety qualification - Part 2: Requirements for testing (IEC 61730-2:2004, modified)	Description words: Applicability classes, Earthing, Insulation test, Leakage currents, Mechanical testing, Photovoltaics, Qualification approval, Qualifications, Safety measures, Safety requirements, Solar cells, Solar energy, Solar power, Solar technics, Temperature test, Testing, Visual inspection (testing)

## D6.1.2 Building Codes BIPV in Europe

	Standards & guidelines	Title	Remarks
		Photovoltaic (PV) module safety qualification - Part 2: Requirements for testing	This part of IEC 61730 describes the testing requirements for photovoltaic (PV) modules in order to provide safe electrical and mechanical operation during their expected lifetime. Specific topics are provided to assess the prevention of electrical shock, fire hazards, and personal injury due to mechanical and environmental stresses
<i>Inverters</i>			
<i>Support structure</i>			
<b>System</b>	EN 13501-5:2006 en	Fire classification of construction products and building elements - Part 5: Classification using data from external fire exposure to roofs tests	This European Standard provides the fire performance classification procedures for roofs/roof coverings exposed to external fire based on the four test methods given in ENV 1187:2002.
	EN 1363-1:1999 en	Fire resistance tests - Part 1: General requirements	Establishes the general principles for determining the fire resistance of various elements of construction when subjected to standard fire exposure conditions. Alternative and additional procedures to meet special requirements are given in prEN 1363-2.
	EN 1363-2:1999 en	Fire resistance tests - Part 2: Alternative and additional procedures	Specifies alternative heating conditions and other procedures that may need to be adopted under special circumstances.
	EN ISO 11925-2 / EN 13823	Reaction to fire tests - Ignitability of building products subjected to direct impingement of flame - Part 2: Single-flame source test (ISO 11925-2:2002) / Reaction to fire tests for building products - Building products excluding floorings exposed to the thermal attack by a single burning item	English translation of : Essais de réaction au feu - Allumabilité des produits de bâtiment soumis à l'incendie directe de la flamme - Partie 2: Essai à l'aide d'une source à flamme unique (ISO 11925-2:2002) /Essais de réaction au feu des produits de construction - Produits de construction à l'exclusion des revêtements de sol exposés à une sollicitation thermique provoquée par un objet isolé en feu
	NVN-ENV 1187:2003/A1:2005	Test methods for external fire exposure to roofs	Fire behavior of roofs on external exposure to flying brands. Basket filled with softwood fibers.

**D6.1.2 Building Codes BIPV in Europe**

	<b>Standards &amp; guidelines</b>	<b>Title</b>	<b>Remarks</b>
	EN 1991-1-2: 2002	Eurocode 1 - Actions on structures -	Part 1-2: General actions - Actions on structures exposed to fire <i>Eurocode 1 will come in charge (including the National Annex) in 2010</i>
	EN-ISO 1182:2002 en	Reaction to fire tests for building products - Non-combustibility test	Specifies a method of test for determining the combustibility performance of homogeneous building material under specified conditions but is not applicable to the testing of products which are coated, faced or laminated. A commentary on the test is given in annex A.
	EN-ISO 1716:2002 en	Reaction to fire tests for building products - Determination of the heat of combustion	Specifies a method for the determination of the heat of combustion of building products at constant volume in a bomb calorimeter.
	EN 501:1994 en	Roofing products from metal sheet - Specification for fully supported roofing products of zinc sheet	This EN specifies requirements for roofing products used for assembly into coverings for pitched roofs, made from Zinc Copper Titanium alloy sheet with or without additional organic coatings. This standard establishes the general characteristics, definitions, classifications, labelling and quality control for the products.
<b>Installation</b>			
<b>Maintenance</b>			

**9.4 Hygiene, health and the environment**

	<b>Standards &amp; guidelines</b>	<b>Title</b>	<b>Remarks</b>
<b>Components</b>			
<i>Modules</i>			
<i>Inverters</i>			
<i>Support structure</i>			
<b>System</b>	EN 61173:1994	Overvoltage protection for photovoltaic (PV) power generating systems - (IEC 61173:1992)	Guide (IEC 61173:1992)
	EN 62305-1:2006	Protection against lightning -	Part 1: General principles (IEC 62305-1:2006)

**D6.1.2 Building Codes BIPV in Europe**

	<b>Standards &amp; guidelines</b>	<b>Title</b>	<b>Remarks</b>
	EN 62305-2:2006	Protection against lightning -	Part 2: Risk management (IEC 62305-2:2006)
	EN 62305-3:2006	Protection against lightning -	Part 3: Physical damage to structures and life hazard (IEC 62305-3:2006, modified)
	EN 62305-4:2006	Protection against lightning -	Part 4: Electrical and electronic systems within structures (IEC 62305-4:2006)
	EN 12154: 1999 and EN 12155: 2000	Curtain walling	EN 12154: Water tightness- Performance requirements and classification EN 12155: Water tightness – laboratory test under static pressure
	EN 86	Testing of windows. Water tightness under static pressure	
	prEN 12154	Curtain walling. Water tightness. Performance requirements and classification	Classes: water spray with zero pressure and water spray with pressure difference
	prEN 12155	Curtain walling. Water tightness. Laboratory test under static pressure	
<b>Installation</b>			
<b>Maintenance</b>			

**9.5 Safety in use**

	<b>Standards &amp; guidelines</b>	<b>Title</b>	<b>Remarks</b>
<b>Components</b>			
<i>Modules</i>	EN 50380	Datasheet and Nameplate Information for Photovoltaic Modules	
	EN-IEC 61730-1:2007 en; fr	Photovoltaic (PV) module safety qualification	Part 1: Requirements for construction
	EN-IEC 61730-2:2007 en; fr	Photovoltaic (PV) module safety qualification	Part 2: Requirements for testing
	IEC 60891:1987-04	Procedures for temperature and irradiance corrections to measured I-V characteristics of crystalline silicon photovoltaic devices	<i>Related to</i> IEC 60891:1987 IDT, IEC 60891:1987/A1:1992 IDT, EN 60891:1994 IDT

## D6.1.2 Building Codes BIPV in Europe

	Standards & guidelines	Title	Remarks
	IEC 60904 series	Photovoltaic devices.	The IEC 60904 series is a coherent system of standards for defining the electrical features of PV devices. These standards are mainly for interest of manufacturers, test labs and research institute and of minor interest of end-users
	IEC 60904-1	Photovoltaic devices.	Part 1: Measurement of photovoltaic current-voltage characteristics
	IEC 60904-2.	Photovoltaic devices.	Part 2: Requirements for reference solar cells
	IEC 60904-3	Photovoltaic devices with spectral irradiance data	Part 3: Measurement principles for terrestrial photovoltaic (PV) solar devices with spectral irradiance data
	IEC 60904-5	Photovoltaic devices.	Part 5: Determination of the equivalent cell temperature (ECT) of photovoltaic (PV) devices by the open circuit method
	IEC 60904-6	Photovoltaic devices.	Part 6: Requirements for reference solar modules
	IEC 60904-7	Photovoltaic devices.	Part 7: Computation of spectral mismatch error introduced in the testing of a photovoltaic device
	IEC 60904-8 : 1998 en; fr	Photovoltaic devices.	Part 8: Measurement of spectral response of a photovoltaic (PV) device
	IEC 60904-9 : 1995 en ; fr	Photovoltaic devices.	Part 9: Solar simulator performance requirements
	IEC 60904-10 : 1998 en ; fr	Photovoltaic devices.	Part 10: Methods of linearity measurement
Inverters	IEC 60755:1983 + A1: 1983 + A2: 1983	General requirements for residual current operating protective devices	The primary function of residual current devices is to give protection against "indirect contact", but with devices of adequate sensitivity (that is units having operating residual currents not exceeding 30 mA) there is the additional benefit that, should other methods of protection fail, the device will give a high degree of protection to a user making direct contact with a live conductive part
	EN 50081-1	Generic Requirements (residential, commercial, and light industry)	Not mentioned in NNI
	EN-IEC 60950-1:2006/C1:2006 en;fr	Information technology equipment - Safety - Part 1: General requirements	

## D6.1.2 Building Codes BIPV in Europe

	Standards & guidelines	Title	Remarks
	EN-IEC 61000-6-3:2001 en;fr	Electromagnetic compatibility (EMC) - Part 6-3: Generic standards - Emission standard for residential, commercial and light-industrial environments	Outlines the emission requirements which applies to electrical and electronic apparatus intended for use in the residential, commercial and light-industrial environment for which no dedicated product or product-family emission standard exists. Disturbances in the frequency range 0 Hz to 400 GHz are covered. Apparatus designed to radiate electromagnetic energy for communication purposes are excluded from this standard.
	EN 60529:1991 + A1:2000	Degrees of protection provided by enclosures (IP code)	(IEC 60529:1989 + A1:1999)
	IEC 62109-1	Safety of power converters for use in photovoltaic systems	Part 1: General requirements
	EN 60146-1-1:1993	Semiconductor convertors; general requirements and line-commutated convertors;	part 1-1: specifications of basic requirements (IEC 60146-1-1:1991); draft 2007 available
	EN 60146-1-3:1993	Semiconductor convertors; general requirements and line-commutated convertors;	part 1-3: transformers and reactors (IEC 60146-1-3:1991)
	IEC 61727:2004 en;fr	Photovoltaic (PV) systems - Characteristics of the utility interface	This International Standard applies to utility-interconnected photovoltaic (PV) power systems operating in parallel with the utility and utilizing static (solid-state) non-islanding inverters for the conversion of DC to AC.
<i>Support structure</i>			
<b>System</b>	EN 50160.	[1] Voltage characteristics of electricity supplied by public distribution systems	
	IEC 60364-7-712:2002 en;fr	Electrical installations of buildings - Part 7-712: Requirements for special installations or locations - Solar photovoltaic (PV) power supply systems	Apply to the electrical installations of PV power supply system including systems with AC modules.
	EN 60947-1:2004	Low-voltage switchgear and controlgear -	Part 1: General rules (IEC 60947-1:2004)

**D6.1.2 Building Codes BIPV in Europe**

	<b>Standards &amp; guidelines</b>	<b>Title</b>	<b>Remarks</b>
	IEC 61173	Overvoltage protection for photovoltaic (PV) power generating systems - Guide (IEC 61173:1992)	Gives guidance on the protection of overvoltage issues for both stand-alone and grid-connected photovoltaic power generating systems.
<b>Installation</b>	EN 50110: 1998/C1:2001 en	Operation of electrical installations (National Annexes)	
	IEC 62446; VDE 0126-23:2007	Grid connected photovoltaic systems -	Minimum system documentation, commissioning tests and inspection requirements (IEC 82/460/CD:2006); draft
<b>Maintenance</b>			

**9.6 Protection against noise**

	<b>Standards &amp; guidelines</b>	<b>Title</b>	<b>Remarks</b>
<b>Components</b>			
<i>Modules</i>			
<i>Inverters</i>			
<i>Support structure</i>			
<b>System</b>	EN-ISO 717-2:1997 en	Acoustics - Rating of sound insulating in buildings and of building elements -	Part 1: Airborne sound insulation (ISO 717-1:1996 + AM1:2006) Part 2: Impact sound insulation-
	EN 12354-3: 2000	Building acoustics - Estimation of acoustic performance of buildings from the performance of elements	Part 3: Airborne sound insulation against outdoor sound
<b>Installation</b>	IEC 60364-7-714:1996 en;fr	Electrical installations of buildings - Part 7: Requirements for special installations or locations - Section 714: External lighting installations	The requirements of part 7 supplement, modify or replace certain of the general requirements of the IEC 364. The numbers following the particular number of section 714 are those of the corresponding parts, chapters, sections or clauses of IEC Publication 364. The absence of reference to a chapter, a section or a clause means that the general requirements of IEC 364 are applicable.

	Standards & guidelines	Title	Remarks
<b>Maintenance</b>			

### **9.7 Energy, economy and heat retention**

	Standards & guidelines	Title	Remarks
<b>Components</b>			
<i>Modules</i>	EN 674:1997	Glass in building - Determination of the thermal transmittance (U value) -	Guarded hot plate method
	EN 675:1997	Glass in building - Determination of the thermal transmittance (U value) -	Heat flow meter method
<i>Inverters</i>			
<i>Support structure</i>			
<b>System</b>	(prEN 12152)	Limitation of air permeability	Classes: different pressure levels are applied by which the air permeability $m^3/m^2/h$ is measured.
<b>Installation</b>			
<b>Maintenance</b>			

## 10 Results

In table 1 an overview is given of the European (EN) and IEC standards (EN-IEC) as a result of the inventory given by the investigated countries. Of each of the six 'essential requirements' categories can be seen which subjects are well standardized and which categories lack standardization. Also can be seen at which level of the BIPV system the standards do apply.

Table 1 Overview of availability European and IEC standards of BIPV

	<b>Mechanical resistance and stability</b>	<b>Safety in case of fire</b>	<b>Hygiene, health and the environment</b>	<b>Safety in use</b>	<b>Protection against noise</b>	<b>Energy, economy and heat retention</b>
<b>1 Components</b>						
<i>1.1 Modules</i>	+	+	-	+	-	+/-
<i>1.2 Inverters</i>	+/-	-	-	+	-	-
<i>1.3 Support structure</i>	+/-	-	-	-	-	-
<b>2 System</b>	+	+	+	+/-	+/-	+/-
<b>3 Installation</b>	-	-	-	-	+/-	-
<b>4 Maintenance</b>	-	-	-	-	-	-

+	More than 5 standards and guidelines
+/-	1 - 5 standards and guidelines
-	No standards or guidelines

As can be seen, on the subjects 'Mechanical resistance and stability', 'safety in case of fire' and 'safety in use' a larger number of standards available. It can be noticed that they are mainly focused on 'modules' and 'system', however. On the subjects 'Hygiene, health and the environment', 'Protection against noise' and 'Energy, economy and heat retention' only few standards are given in the inventory.

It should be remarked that the absence of standards in this overview does not necessarily has to mean that this is a problem. It might well be the case that the subject is less relevant for some BIPV elements. It might also be possible that the subject is covered in standards which are categorized at element level. For instance 'system' is a broad term and therefore it can cover items which are related to 'system-components' like modules, inverters and support structure as well.

## D6.1.2 Building Codes BIPV in Europe

---

### *Eurocodes: building codes for Europe*

As can be seen from the country overviews and the EC standards the structural Eurocodes are becoming more and more important. The Eurocodes are new structural design codes for building and civil engineering works. Eurocodes are applicable to whole structures and to individual elements of structures and cater for the use of all the major construction materials such as concrete, steel, timber, masonry and aluminum. The Eurocodes will become the Europe wide means of designing civil and structural engineering works and so, they are of vital importance to both the design and construction sectors of the civil and building industries.

CEN, as the official European standards body, is developing these Eurocodes. The CEN Technical Committee 250 has been working since the early nineties to develop the Eurocodes as 'pre-standards'. The committee is now transforming the documents into European Standards, which will be mandatory in the European member states after a period of co-existence with the national standards. More information: [www.cenorm.be](http://www.cenorm.be).

The codes become the means to design construction works in Europe and to check their conformity to essential requirements, which are defined in the Construction Product Directive. Such requirements must, subject to normal maintenance, be satisfied for an economically reasonable working life. They check if products are fit for their intended use and also safe to use.

New developed BIPV products and the application of these products in buildings will have to comply with the national building codes and in the future with the Eurocodes, once they are adopted by all the member states. It is expected that the Eurocodes will also play an important role in the European tendering for building projects and thus BIPV products will have to comply with the requirements for constructions governed by the Eurocodes.

## 11 Conclusions and recommendations

The standardization and regulation on BIPV in Europe is a complex matter. In each country BIPV has to fulfill various regulations and (inter)national standards on electro technical as well as building technical level. This even stretches as far as differences between regions.

Mainly, since BIPV has to deal with these two levels (building and electro technical) it is very difficult to give a complete and up-to-date overview of all BIPV related standards and guidelines in the selected European countries. However, the most relevant standards for BIPV are listed and, by giving an overview, it is pointed out where the hiatuses in BIPV standardization are given.

The overview in table 1 gives good insight in the availability and gaps in the standards and regulations on the essential requirements at different classes and product levels. As can be seen, on the subjects 'Mechanical resistance and stability', 'safety in case of fire' and 'safety in use' a larger number of standards available. It can be noticed that they are mainly focused on 'modules' and 'system', however. On the subjects 'Hygiene, health and the environment', 'Protection against noise' and 'Energy, economy and heat retention' only few standards are available.

This overview of building codes and regulations for Building Integrated PV products will form the basis for determining requirements for test procedures and PV codes to be set up in a following phase of this project. Important aspect will be the interaction between building and electro technical (safety) requirements on a system level.

A possible new BIPV standard (for BIPV products) should be based on the Eurocodes. It is expected that the Eurocodes (once they are adopted by all the member states) will play an important role in the European construction sector and BIPV products and systems will have to comply with the requirements for constructions governed by the Eurocodes.

Finally the test procedures and PV codes will have to be implemented in national or European law to become effective.

## Annex 1 Essential requirements as described in the CPD

*The products must be suitable for construction works which (as a whole and in their separate parts) are fit for their intended use, account being taken of economy, and in this connection satisfy the following essential requirements where the works are subject to regulations containing such requirements. Such requirements must, subject to normal maintenance, be satisfied for an economically reasonable working life. The requirements generally concern actions that are foreseeable.*

### **1. Mechanical resistance and stability**

*The construction works must be designed and built in such a way that the loads that are liable to act on it during its constructions and use will not lead to any of the following:*

- a) *collapse of the whole or part of the work;*
- b) *major deformations to an inadmissible degree;*
- c) *damage to other Parts of the works or to fittings or installed equipment as are result of major deformation of the load-bearing construction;*
- d) *damage by an event to an extent disproportionate to the original cause*

### **2. Safety in case of fire**

*The construction works must be designed and built in such a way that in the event of an outbreak of fire:*

- *the load-bearing capacity of the construction can be assumed for a specific period of time,*
- *the generation and spread of fire and smoke within the works are limited.*
- *the spread of the fire to neighbouring construction works is limited,*
- *occupants can leave the works or be rescued by other means.*
- *the safety of rescue teams is taken into consideration.*

### **3. Hygiene, health and the environment**

*The construction work, must be designed and built in such a way that it will not be a threat to the hygiene or health of the occupants or neighbours, in particular as a result of any of the following:*

- *the giving-off of toxic gas,*
- *the presence of dangerous particles or gases in the air.*
- *the emission of dangerous radiation*
- *pollution or poisoning of the water or soil,*
- *faulty elimination of waste water, smoke, solid or liquid wastes,*
- *the presence of damp in parts of the works or on surfaces within the works.*

### **4. Safety in use**

*The construction work must be designed and built in such a way that it does not present unacceptable risks of accidents in service or in operation such as slipping, falling, collision, burns, electrocution, injury from explosion.*

### **5. Protection against noise**

*The construction works must be designed and built in such a way that noise perceived by the occupants or people nearby is kept down to a level that will not threaten their health and will allow them to sleep, rest and work in satisfactory conditions.*

### **6. Energy economy and heat retention**

*The construction works and its heating, cooling and ventilation installations must be designed and built in such a way that the amount of energy required in use shall be low, having regard to the climatic conditions of the location and the occupants.*

## Annex 2 Summary Dutch Building Regulations

[Source PRESCRIPT - Task 1]

<b>Part 1. Prescriptions for safety</b>	
<b>paragraph 1 Constructive safety</b>	
	Reference is made to prescriptions (strength, fire safety) that apply for load bearing support constructions
	<i>Article 2, constitution 1, 2, 3, 4 and 6</i>
1.	In order for a building construction to be durably resistant against fundamental load combinations, this construction shall not exceed the limits that are laid down in NEN 6702.
2.	The construction shall not exceed the limits that are laid down in NEN 6702 in case of special loads.
3.	This not exceeding the limits shall be determined according to: <ul style="list-style-type: none"> <li>d. NEN 2608 if the construction is made of glass.</li> <li>e. NEN 6707 if the construction is made of roof covering material</li> </ul>
4.	In case other material is used than mentioned in [4], (metal, stone, wood, glass, roofs covering), NEN 6700 applies.
6.	The load carrying support construction of buildings with a highest floor of $\leq 13$ m should have a total failure resistance of $\geq 90$ minutes. Buildings having floors at higher levels should have a support structure with a total fire failure resistance $\geq 120$ minutes.
<b>Paragraph 3 Fire safety</b>	
	<i>Article 12, constitution 7</i>
7.	A roof may not cause a fire hazard, according to NEN 6063.
	<i>Article 13, constitution 1, 5 and 6</i>
1.	Construction parts other than roofs, [..], shall be at least class 4 as mentioned in NEN 6065, regarding fire propagation. (Chapter VI, paragraph 3, article 184, constituent 7)
5.	External partition constructions of residential buildings that have a floor in a living area higher than 5 m above neighboring terrain [..] shall be class 1 according to NEN 6065.
6.	[5] does not apply for parapets of which the top is not higher than 1.5 m above neighboring terrain.
	<i>Article 14, constitution 1 and 9</i>
1.	1. The resistance against fire penetration and fire spread between one residential building and another on the same lot shall be 60 minutes according to NEN 6082 9. The resistance against fire penetration and fire spread between one residential building and another on another lot shall be 60 minutes according to NEN 6082, taking into account that the other building is taken to be an identical but mirror imaged building.
	<i>Article 16, constitution 2</i>
2.	The inside part of a building construction must have a limited smoke density $\leq 10$ /m.
3.	Constitution 2 must be deviated, if the inside area makes part of an escape route the smoke density is limited to $\leq 5.4$ /m ( $\leq 2.2$ /m) in case the building part is a class 1 (class 2) according to NEN 6065.

<b>part 2. Prescriptions for health</b>	
<b>paragraph 1 Protection against harmful or troublesome influences</b>	
	<i>Article 22</i>
1.	The characteristic noise barrier as mentioned in NEN 5077 [..] shall be equal to the difference of the noise load and 35 dB, but at least 20 dB.
	<i>Article 26 (resistance against humidity from outside)</i>
1.	An external partition construction shall be watertight according to NEN 2778.
	<i>Article 27 (resistance against humidity from inside)</i>
1.	The ratio between the temperature difference at the temperature at the inside of a building part and the temperature outside and the temperature difference of the inside and outside temperature must be $\geq 0.65$ .
	<i>Article 29</i>

**D6.1.2 Building Codes BIPV in Europe**

---

1. 1. The roof shall have a facility to collect and drain rain water. This facility must have the possibility to connect it to the public sewer.

*Article 33*

By regulations of ministry, regulations may be issued to prevent the use of unacceptable poisonous, irritating or ionising materials as building material.

**paragraph 3 Protection against vermin**

*Article 35*

1. In an external partition construction no enclosable openings are allowed wider than 0,01 m.
2. [1] does not hold if the opening is the end of a vertical duct.

**paragraph 5 Daylighting**

*Article 39*

1. The total of external partition constructions shall have an equivalent day lighting area of at least 10% of the floor area of the living area, according to NEN 2057.
2. The day lighting area shall be at least 0,5 m<sup>2</sup>.

**Part 4. Prescriptions for energy efficiency**

**paragraph 1 limitation of heat loss**

*Article 70*

1. The external partition construction shall have a thermal resistance of at least 2,5 m<sup>2</sup> K/W according to NEN 1068.
2. Windows, doors and equivalent shall have a thermal resistance of at least 4,2 m<sup>2</sup> K/W according to NEN 5128

*Article 71*

1. The total of external partition constructions (with the outside or non-insulated building parts or crawl space) shall not allow a larger airflow than 0,2 m<sup>3</sup>/s, as specified in NEN 2686.

*Article 71a*

1. The total energy performance coefficient of the total residential building may be  $\leq 0.8$  at maximum, determined by the calculation method of NEN 5128.